



RHINO-RACK

43129, 43130, 43131 & 43176 Rhino Pioneer Roller Kit

Place these instructions in the vehicle's glove box after installation is complete.

Important: Please read these instructions carefully prior to installation.
Please refer to your fitting instruction to ensure that the alloy tray is installed correctly.
Check the contents of this kit before commencing fitment and report any discrepancies.

Roller Kit	Suits Trays	
	Platform	Tradie
43129	42100, 42102, 42107 & 42109	45100, 45102, 45107 & 45109
43130	42101, 42103 & 42110	45101, 45103 & 45110
43131	42104, 42108, 42111, 42112 & 42113	45104, 45108 & 45111
43176	42105	-

Item	Component Name	Qty	Part No.
1	Plastic Roller	1	R020
2	Aluminium Roller	1	RRC024
3	Pioneer Roller Bracket - LH	1	CA1228
4	Pioneer Roller Bracket - RH	1	CA1229
5	Roller Bush - Acetal	2	M023
6	M10 Nyloc Nut	2	N010
7	M10 Flat Washer	4	W023
8	M10 Nut	2	N021
9	M10 x 90mm Hex Bolt	2	B055
10	M6 x 50mm Coach Bolt	2	B204
11	M6 x OD16 Flat Washer	2	W031
12	M6 Nyloc Nut	2	N013
13	Fitting Instructions	1	R314

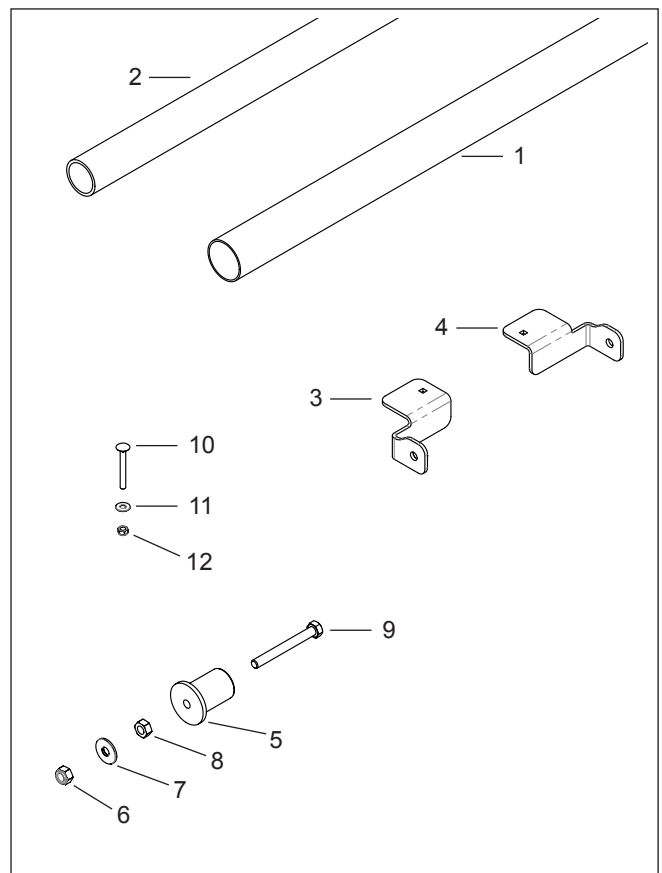

Care Instruction

Clean alloy tray prior to fitting the Pioneer Roller.

Tools Required

- Electric Drill with 6.5mm Drill Bit
- 10mm Spanner
- 16mm Spanner
- 17mm Spanner

Rhino-Rack
3 Pike Street, Rydalmere,
NSW 2116, Australia.
(Ph) (02) 9638 4744
(Fax) (02) 9638 4822

Document No: R314
Prepared By: Nigel Greig
Authorised By: Chris Murty

Issue No: 05
Issue Date: 15/04/2015

These instructions remain the property of Rhinorack Australia Pty Ltd and may not be used or changed for any other purpose than intended.



43129 - 43131 Rhino Pioneer Roller Kit

IMPORTANT

Fitment of the roller may interfere with tailgates that lift upwards when opened. To allow clearance between the roller and the tailgate you will have to drill new locations for the Pioneer crossbars. Measure and drill (diameter 8.5mm holes) 60mm back from the specified crossbar locations for your vehicle. This will shift the tray forward on the vehicle and allow adequate clearance for roller fitment.

1 Remove Screws and Drill Rear Extrusion

Remove both the screws on the under side of the rear extrusion as shown below. Drill through the holes where the screws were removed with a 6mm drill bit, drilling right through the tray.

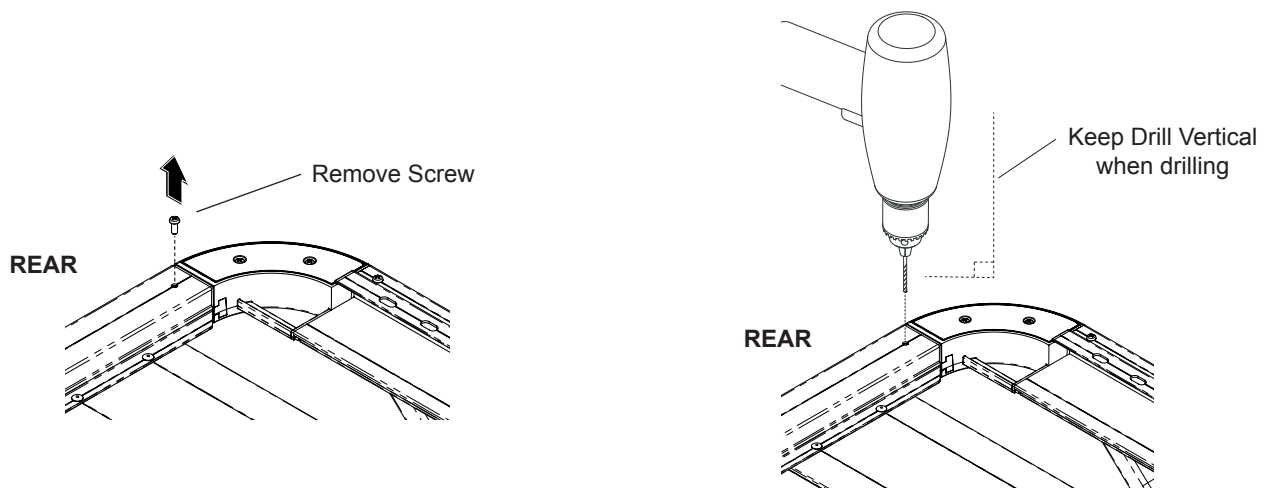

2 Insert Roller Bush Assemblies into Roller Tubes

Slide the aluminium roller inside the plastic roller tube, then insert the roller bush assemblies into the aluminium roller as shown below.

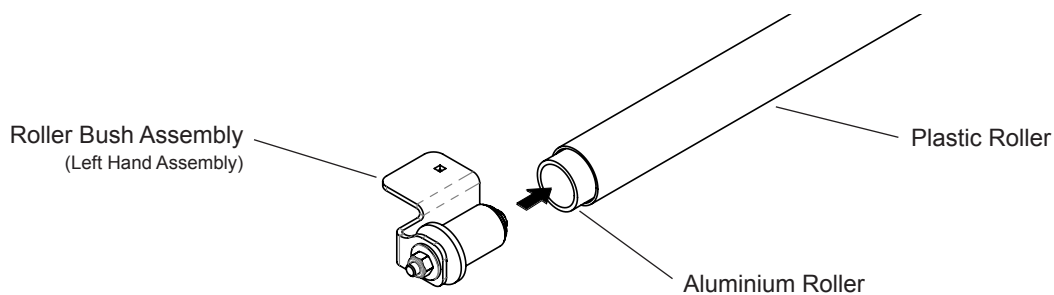

3 Fit Roller to Tray

Place roller on rear of tray and fasten in position with the hardware supplied.

