

MSD INSTALLATION INSTRUCTIONS

MSD-to-Dodge Harness 1998-2003, PN 8884 / 1990-1997, PN 8889

ONLINE PRODUCT REGISTRATION: Register your MSD product online. Registering your product will help if there is ever a warranty issue with your product and helps the MSD R&D team create new products that you ask for! Go to www.msperformance.com/registration.

Parts Included:

1 - MSD Harness

IMPORTANT: Review the Ignition Control Instructions before attempting the installation.

The MSD-to-Dodge Coil Harness is designed to provide a splice-free and simple installation of an MSD Ignition Control to late model Dodge vehicles equipped with the coil shown in Figure 1.

MSD 6 and 7 Series Ignitions

All of the wires connect to the corresponding colored wires (Figure 2). MSD 7 Series Ignitions share the same color wires.

1. Disconnect the connector from the coil and connect it to the MSD PN 8884/PN 8889 Harness.
2. Connect the other end of the Harness to the Coil.
3. Connect the four wires of the Harness to the MSD Ignition Control.

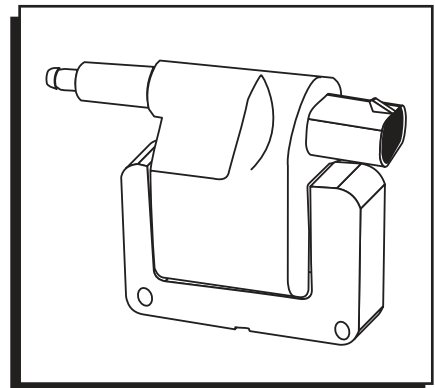

Figure 1 Dodge Coil.

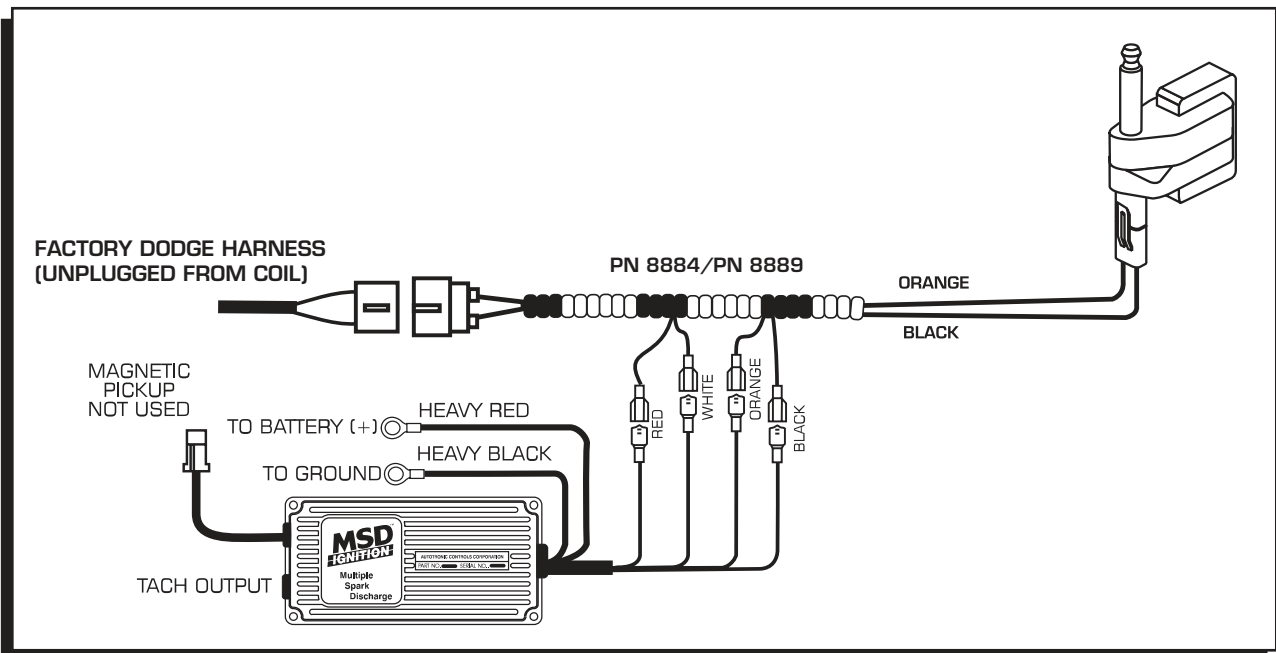

Figure 2 Installation with an MSD 6 or 7 Series Ignition Control.

MSD INSTALLATION INSTRUCTIONS

Installation with an MSD Timing Control

The PN 8884/PN 8889 may still be used when adding an MSD Timing Control. Figure 3 shows a common installation.

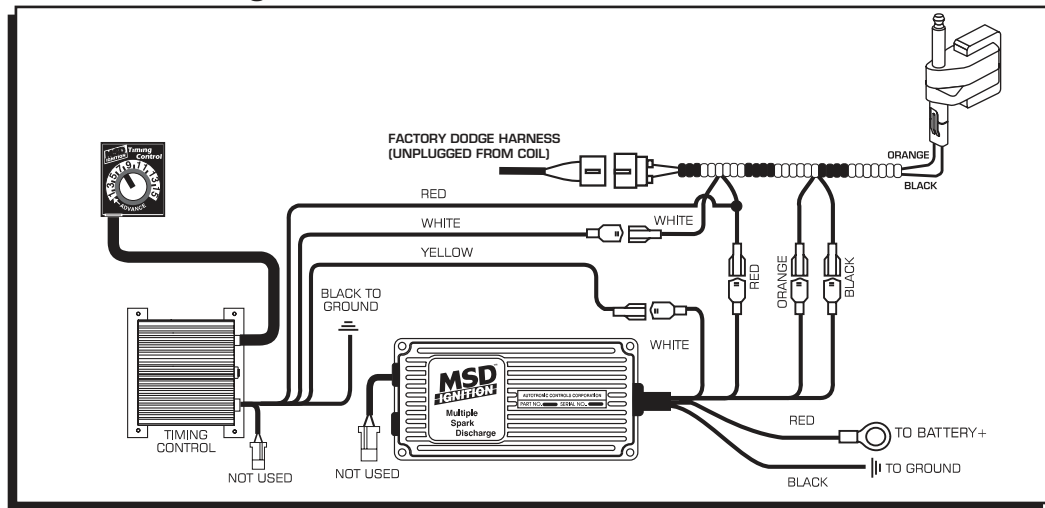

Figure 3 Wiring in an MSD Timing Control with a 6 or 7 Series Ignition.

MSD 5 and Blaster Ignition

Note that the MSD 5 and Blaster Ignitions wire differently than the 6 and 7 Series Ignitions. The Red wire of the MSD 5 or Blaster Ignition connects to **both** the Harness Orange and Red wires (Figure 4).

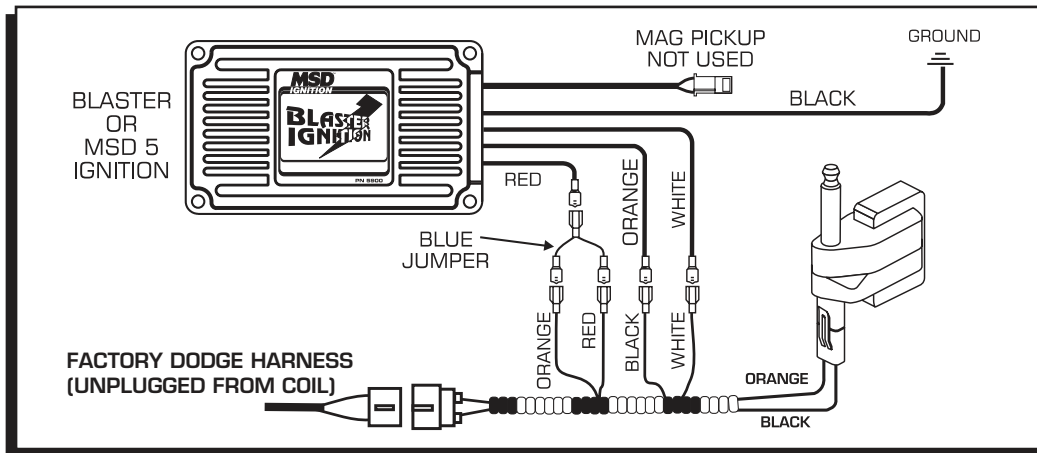

Figure 4 Installation with an MSD 5 or Blaster Ignition.

Service

In case of malfunction, this MSD component will be repaired free of charge according to the terms of the warranty. When returning MSD components for warranty service, **Proof of Purchase** must be supplied for verification. After the warranty period has expired, repair service is based on a minimum and maximum fee.

All returns must have a Return Material Authorization (RMA) number issued to them before being returned. To obtain an RMA number please contact MSD Customer Service at 1 (888) MSD-7859 or visit our website at www.msperformance.com/rma to automatically obtain a number and shipping information.

When returning the unit for repair, leave all wires at the length in which you have them installed. Be sure to include a detailed account of any problems experienced, and what components and accessories are installed on the vehicle. The repaired unit will be returned as soon as possible using Ground shipping methods (ground shipping is covered by warranty). For more information, call MSD at (915) 855-7123. MSD technicians are available from 7:00 a.m. to 5:00 p.m. Monday - Friday (mountain time).