

MSD INSTALLATION INSTRUCTIONS

MSD DIS Coil Interface Module PN 8870

ONLINE PRODUCT REGISTRATION: Register your MSD product online. Registering your product will help if there is ever a warranty issue with your product and helps the MSD R&D team create new products that you ask for! Go to www.msperformance.com/registration.

PARTS INCLUDED:

1 - DIS Coil Interface Module
4 - Retaining Screws
1 - Gasket

SPECIAL TOOLS REQUIRED:

Volt Meter

WARNING: During installation disconnect the battery cables. When disconnecting the battery, always remove negative cable first and install it last.

The MSD DIS Coil Interface Modules are designed to ease installation of an MSD DIS Ignition Control to GM vehicles with coil packs. The Interface Module separates the coil terminals and the ignition module terminals.

The Interface Module has four wires; two White and two Black wires, that connect to the MSD DIS Ignition. The White wires carry the MSD high voltage to the coil terminals.

The Black Wires are responsible for triggering the MSD and supplying a 12 volt ignition source (Figure 1).

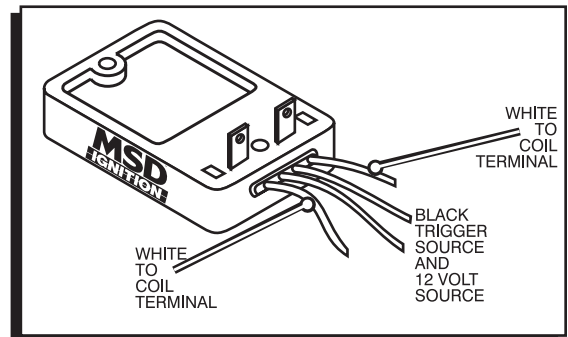
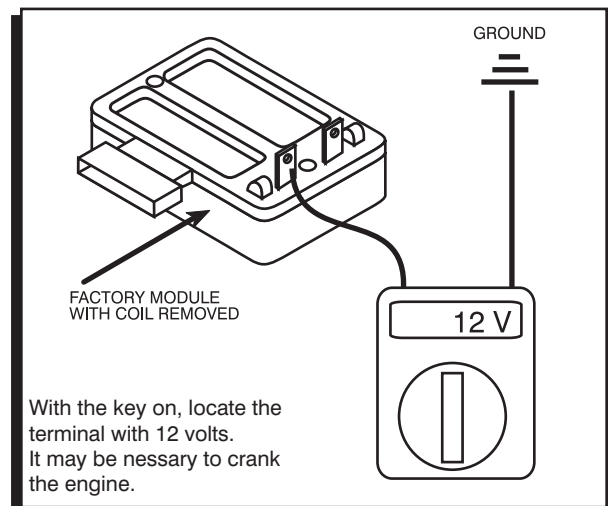

Figure 1 Interface Module Wiring.

Factory ignition modules are not consistent in which terminal of the ignition module supplies 12 volts. In order to properly install the DIS Ignition, you will need to confirm which terminal of the ignition module supplies 12 volts. To do this, a volt meter is required. Before beginning the installation, review the MSD DIS Ignition Control instructions.

1. Mark the location of each spark plug wire and its corresponding coil pack. Remove the spark plug wires from the coils.
2. Remove the two bolts that retain the coil packs and remove the coil from the factory ignition module.
3. There will be two male terminals beneath each coil pack. To ensure which terminal is the 12 volt source, use a volt meter and probe (test) each terminal, with the ignition turned On (Figure 2). A blank diagram is supplied in Figure 4 that allows you to note your vehicle's wiring.

Note: Some applications require that the engine be cranked momentarily before 12 volts are present on the terminal. Check all of the terminals with the key On. If 12 volts is not present, check the terminals while cranking the engine. Note the 12 volt terminals.



With the key on, locate the terminal with 12 volts. It may be necessary to crank the engine.

Figure 2 Identifying 12 Volts.

4. With the 12 volt terminals identified, mark the four wires of the Interface Module (Figure 3). The White wire above the 12 terminal wire will always be Coil Positive (+). The other White wire will always be the coil negative wire.
5. The Black wire above the 12 volt terminal will always be the 12 volt source to the MSD. The other Black wire is the trigger source.
6. Position the MSD Interface Modules on the ignition module and terminals.
7. Remove the protective backing from the gasket and install the gasket with the adhesive side towards the interface module.
8. Install the Coil using the longer bolts supplied with the Interface Module and connect the spark plug wires.
9. Refer to the DIS Ignition Instructions to connect the wires.

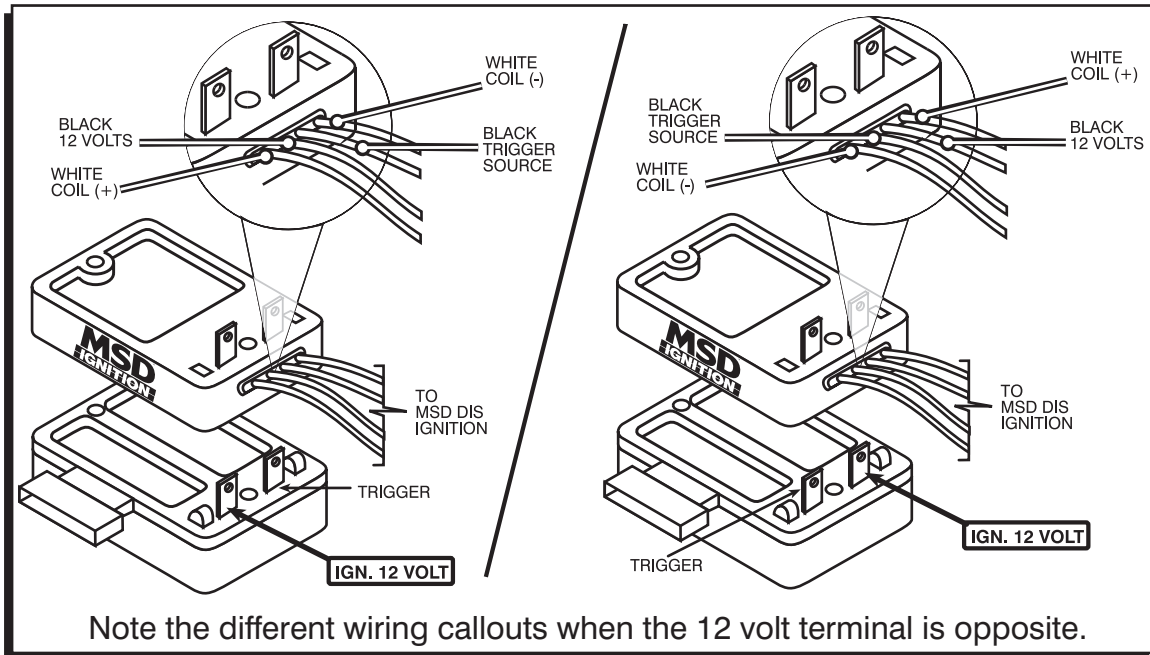

Figure 3 Wiring After Locating the 12 Volts Terminal.

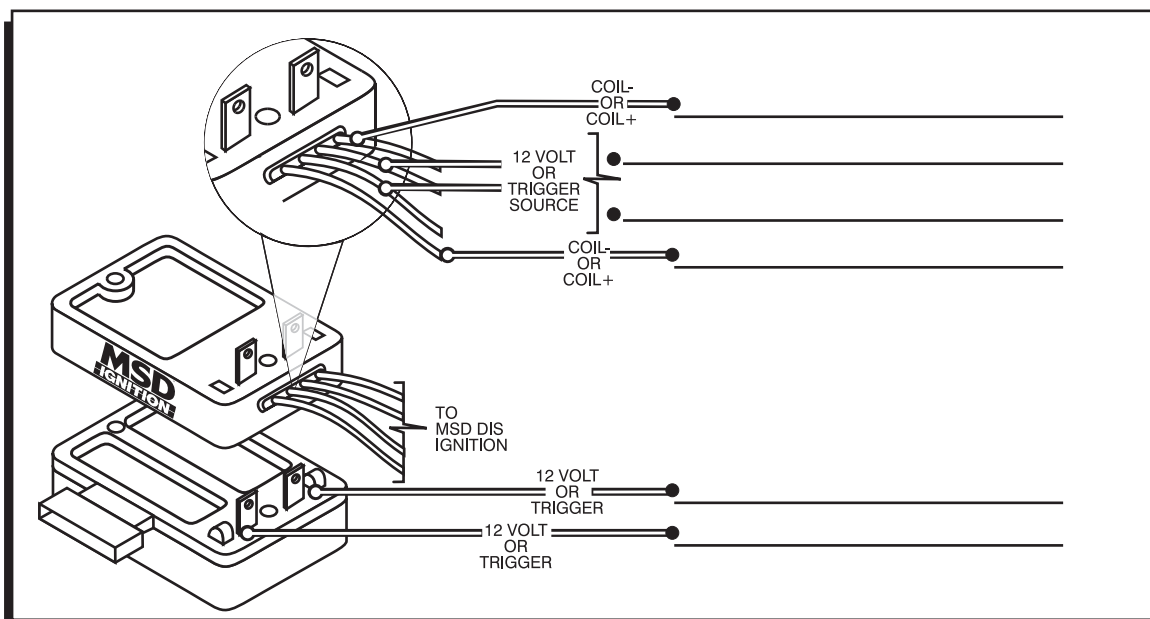

Figure 4 Write in Your 12 Volt Application.

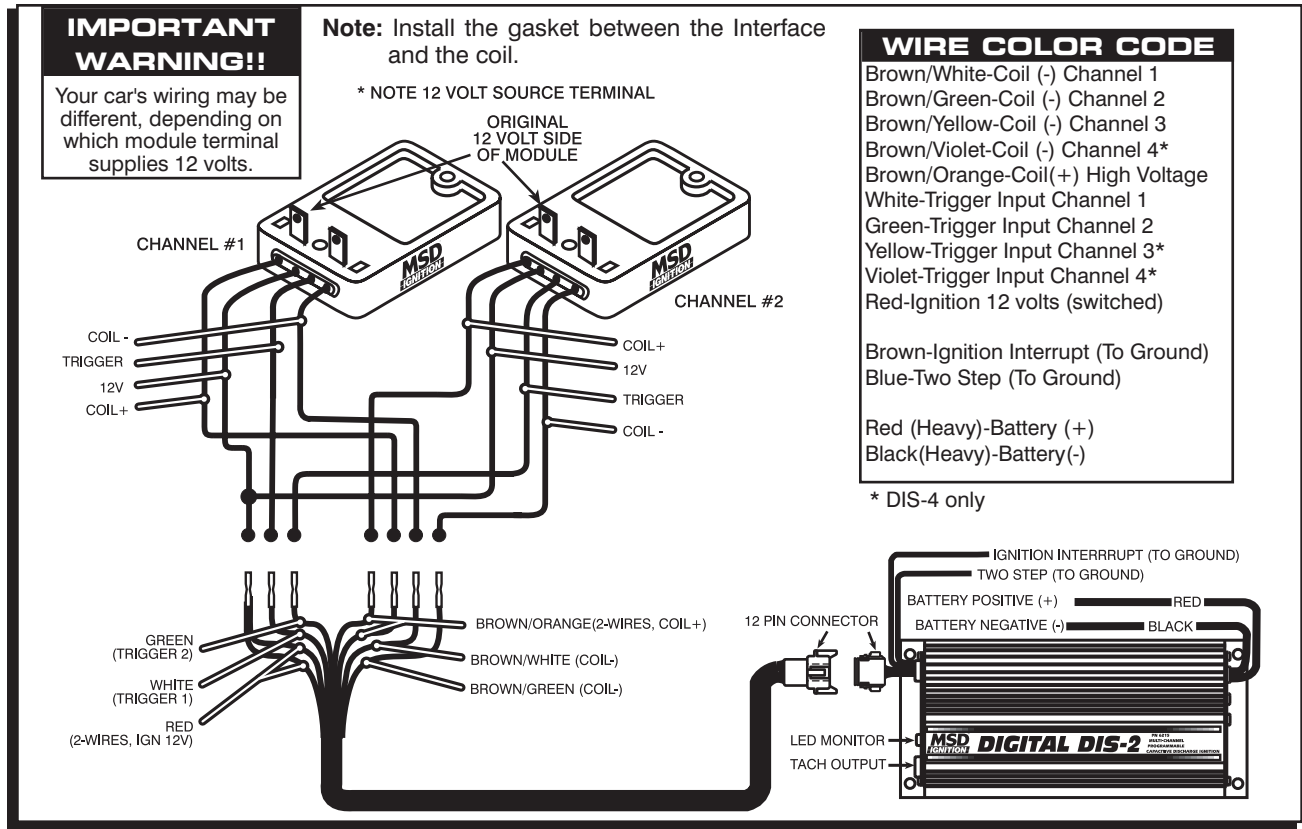

Figure 5 Typical Wiring to a DIS-2 Ignition.

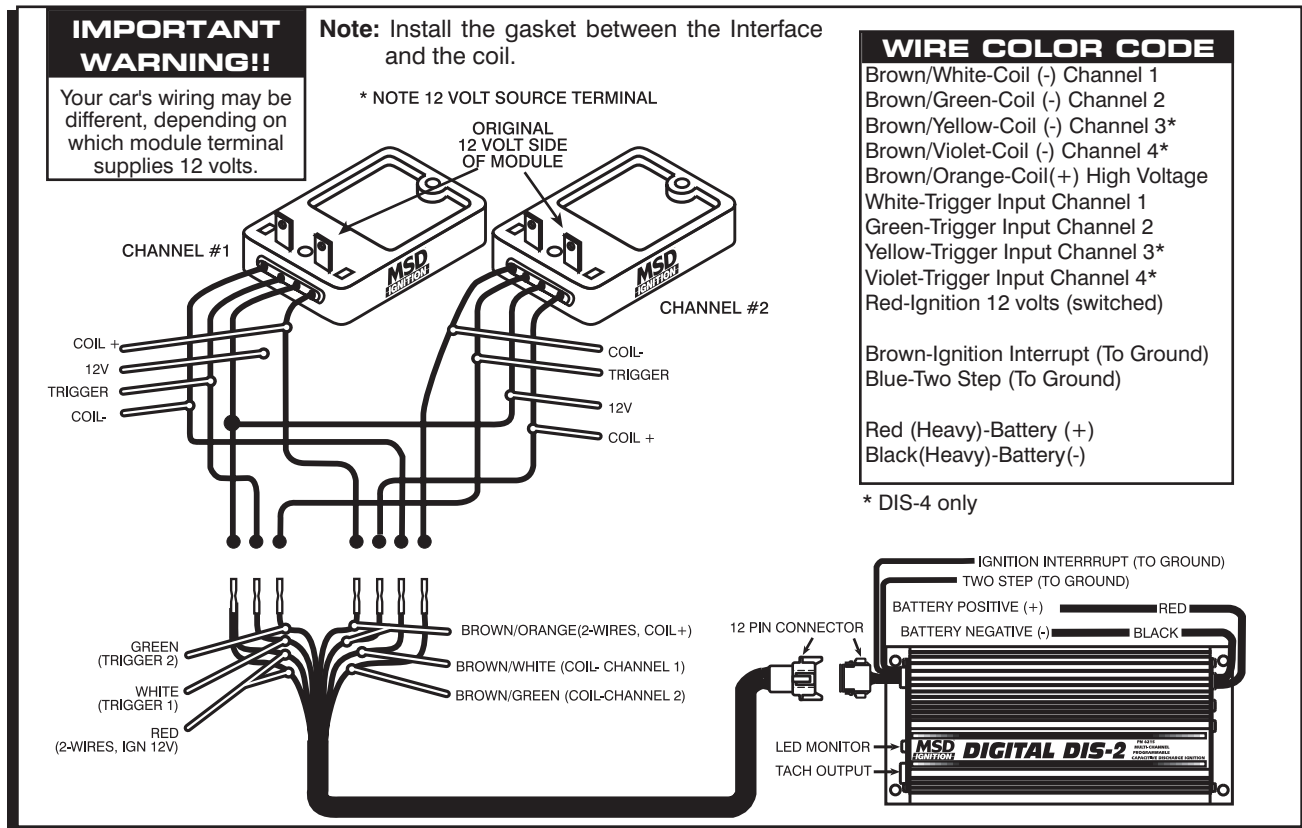
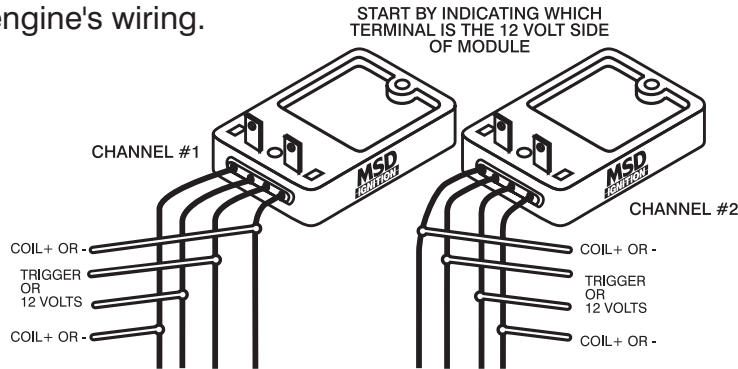

Figure 6 Typical Wiring to a DIS-2 Ignition.

Use this diagram to plot your engine's wiring.

Note: Install the gasket between the Interface and the coil.



WIRE COLOR CODE

Brown/White-Coil (-) Channel 1
 Brown/Green-Coil (-) Channel 2
 Brown/Yellow-Coil (-) Channel 3*
 Brown/Violet-Coil (-) Channel 4*
 Brown/Orange-Coil(+) High Voltage
 White-Trigger Input Channel 1
 Green-Trigger Input Channel 2
 Yellow-Trigger Input Channel 3*
 Violet-Trigger Input Channel 4*
 Red-Ignition 12 volts (switched)

Brown-Ignition Interrupt (To Ground)
 Blue-Two Step (To Ground)

Red (Heavy)-Battery (+)
 Black(Heavy)-Battery(-)

* DIS-4 only

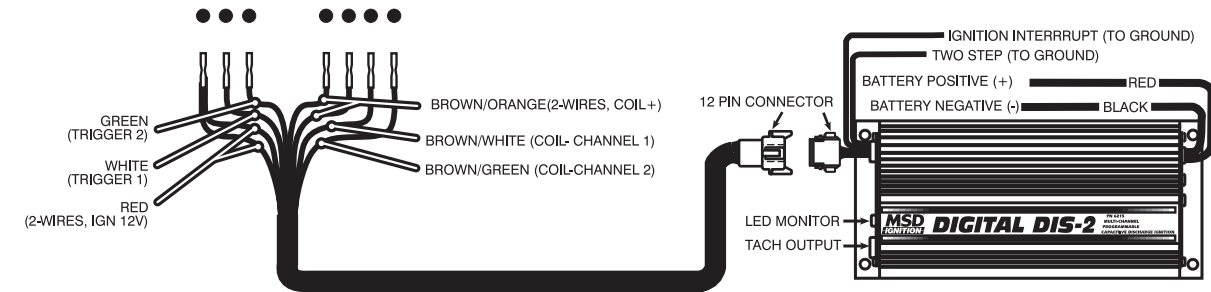

Figure 7 Your Wiring.

Service

In case of malfunction, this MSD component will be repaired free of charge according to the terms of the warranty. When returning MSD components for warranty service, **Proof of Purchase** must be supplied for verification. After the warranty period has expired, repair service is based on a minimum and maximum fee.

All returns must have a Return Material Authorization (RMA) number issued to them before being returned. To obtain an RMA number please contact MSD Customer Service at 1 (888) MSD-7859 or visit our website at www.msdpower.com/rma to automatically obtain a number and shipping information.

When returning the unit for repair, leave all wires at the length in which you have them installed. Be sure to include a detailed account of any problems experienced, and what components and accessories are installed on the vehicle. The repaired unit will be returned as soon as possible using Ground shipping methods (ground shipping is covered by warranty). For more information, call MSD at (915) 855-7123. MSD technicians are available from 7:00 a.m. to 5:00 p.m. Monday - Friday (mountain time).

Limited Warranty

MSD warrants this product to be free from defects in material and workmanship under its intended normal use*, when properly installed and purchased from an authorized MSD dealer, for a period of one year from the date of the original purchase. This warranty is void for any products purchased through auction websites. If found to be defective as mentioned above, it will be repaired or replaced at the option of MSD. Any item that is covered under this warranty will be returned free of charge using Ground shipping methods.

This shall constitute the sole remedy of the purchaser and the sole liability of MSD. To the extent permitted by law, the foregoing is exclusive and in lieu of all other warranties or representation whether expressed or implied, including any implied warranty of merchantability or fitness. In no event shall MSD or its suppliers be liable for special or consequential damages.

*Intended normal use means that this item is being used as was originally intended and for the original application as sold by MSD. Any modifications to this item or if it is used on an application other than what MSD markets the product, the warranty will be void. It is the sole responsibility of the customer to determine that this item will work for the application they are intending. MSD will accept no liability for custom applications.