

LATITUDE

WITH LEER'S EXCLUSIVE



INSTALLATION INSTRUCTIONS & OWNER'S MANUAL

Thank you for purchasing the LEER^R LATITUDETM soft tri-fold tonneau cover. At LEER, we looked at ways to make it better, front to back and inside out. We engineered components with new innovations at every point including our CYNCRTM latching system (patented). The result is a tri-fold that's unlike any cover on the road today.

NOTICE TO INSTALLER: It is recommended you take time to read these instructions before installing the cover even if already familiar with the product. Improvements are often made without prior notice. Always handle the cover and components with care to avoid damage. If you find a part missing or defective, or if you have trouble installing this product, please have the model number ready (located on a tag under the first panel) and call your dealer. When done, these instructions and warranty information must be given to the customer to keep.

NOTICE TO CUSTOMER: Before using this product, read the operating instructions, maintenance and safety sections of this owner's manual and save for future reference. Your new LEER tonneau must be registered to make the warranty valid. Registration information can be found on the back page.

FOR YOUR RECORDS

DATE PURCHASED: _____

SERIAL NUMBER: _____

LEER RETAILER: _____

Master Carton Components	2
Hardware Box Contents.....	2
Pre-Preparation	3
Initial Placement.....	3
Initial Positioning.....	3
Securing the Door.....	4
Packaged Components	5
Anchoring the Front Panel.....	5
Secondary Clamps with Security Buckles.....	5
Installing the Rear Latching System	6
Installing the Rear Strike Plate	6
Adjusting the Strike Plate	7
Adjusting the CYNC Latch	7
Securing an Open Cover for Travel	8
Replacement Parts	9
Clamp Applications.....	10
Quick Start Guide	11
Warranty Policy	12

Unpack components and inspect for missing or damaged components. Open the truck's tailgate and clean truck bed if dirty.

MASTER CARTON COMPONENTS

- 1 SOFT COVER ASSEMBLY (A)
- 1 HARDWARE PACKAGE (See Details Below)



HARDWARE BOX CONTENTS

- 2 EACH REAR CLAMP ASSEMBLY (STYLE VARIES PER CLAMP KIT)
- 2 EACH FRONT TWIST KNOB CLAMP ASSEMBLY
- 1 EACH 2.5MM ALLEN WRENCH
- 1 EACH 5MM ALLEN WRENCH



LATITUDE INSTALLATION INSTRUCTIONS

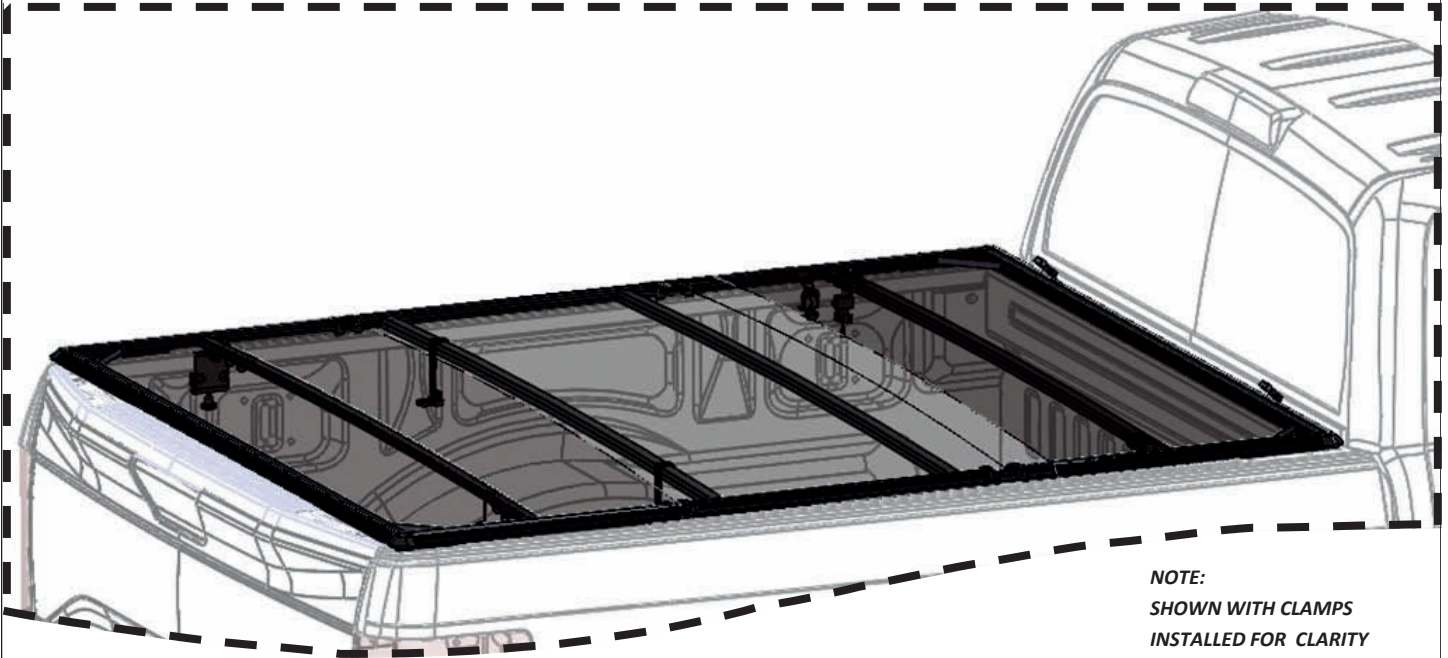

*NOTE:
SHOWN WITH CLAMPS
INSTALLED FOR CLARITY*

1 PRE-PREPARATION



WASH TRUCK BOX
IF DIRTY

2 INITIAL PLACEMENT

PLACE TRUCK COVER
OVER CAB END
OF TRUCK BOX

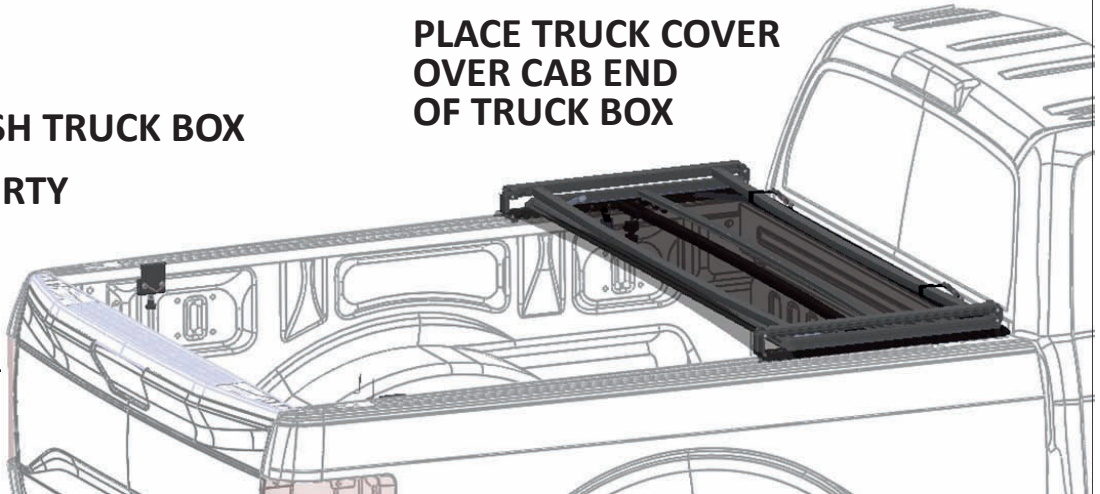

3 INITIAL POSITIONING

UNFOLD THE COVER AND ADJUST
POSITION OVER THE
TRUCK BED FOR
PROPER CAB/
TAIL ALIGNMENT

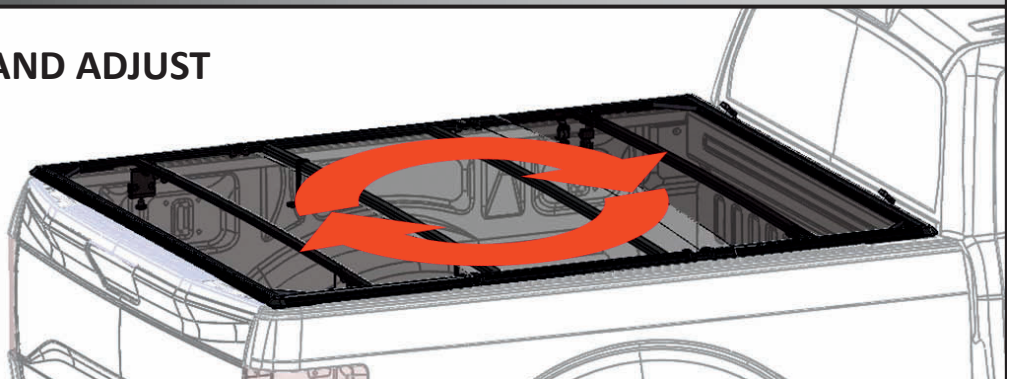

LATITUDE INSTALLATION INSTRUCTIONS

LINE UP FRONT POSITION &
LINE UP SIDE TO SIDE

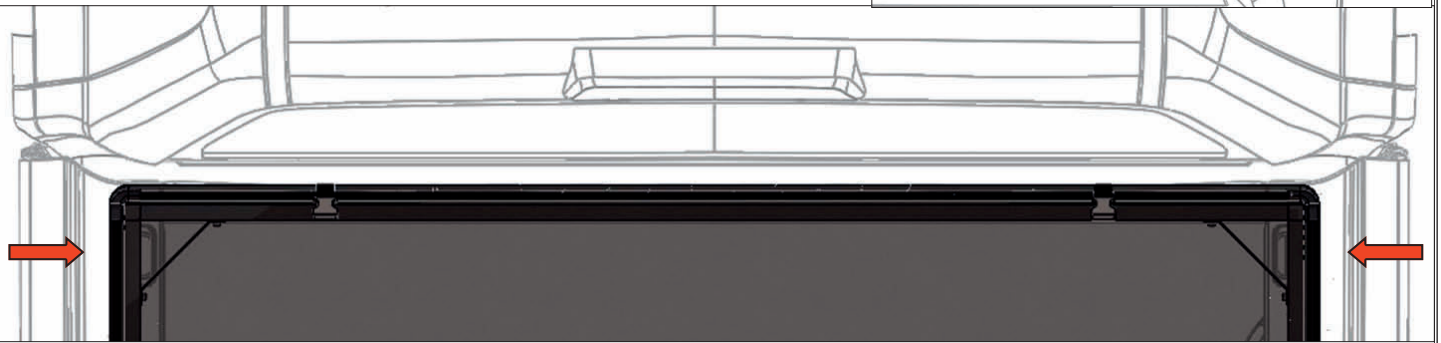
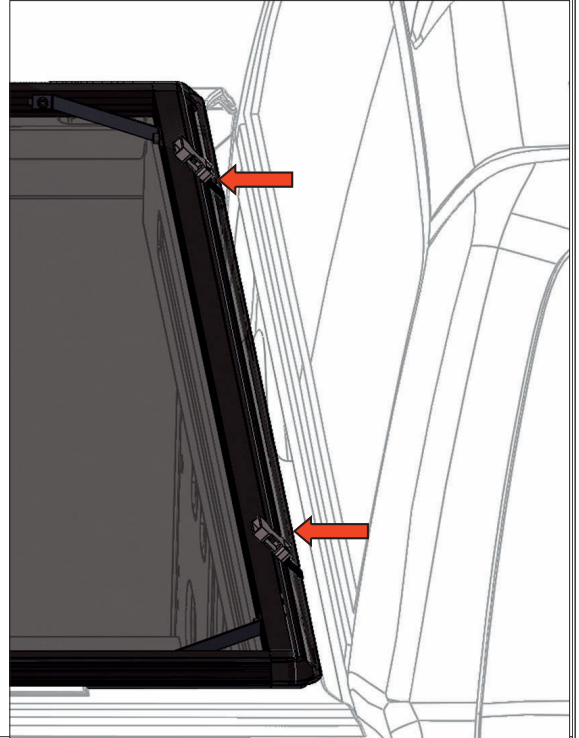

4 SECURING THE COVER

CAREFULLY REFOLD WITHOUT SHIFTING
COVER'S POSITION ON THE TRUCK BED

*NOTE:
SHOWN WITH CLAMPS
INSTALLED FOR CLARITY*

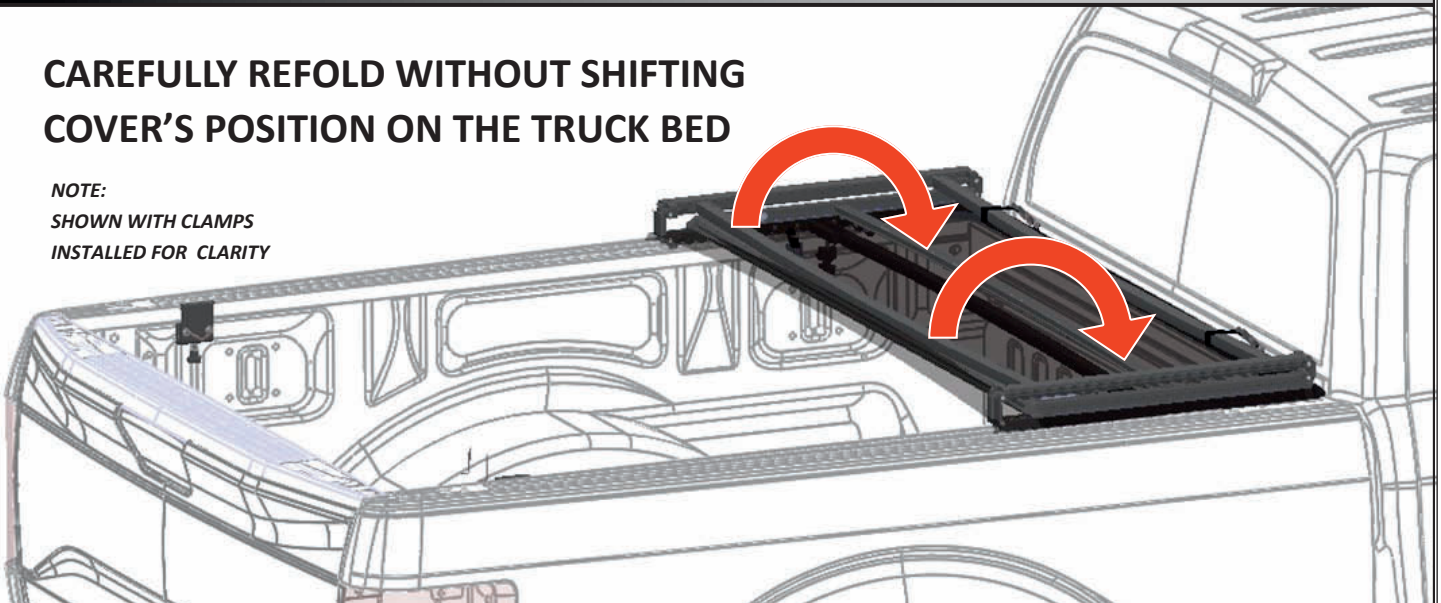

LATITUDE INSTALLATION INSTRUCTIONS

5 ANCHORING THE FRONT PANEL

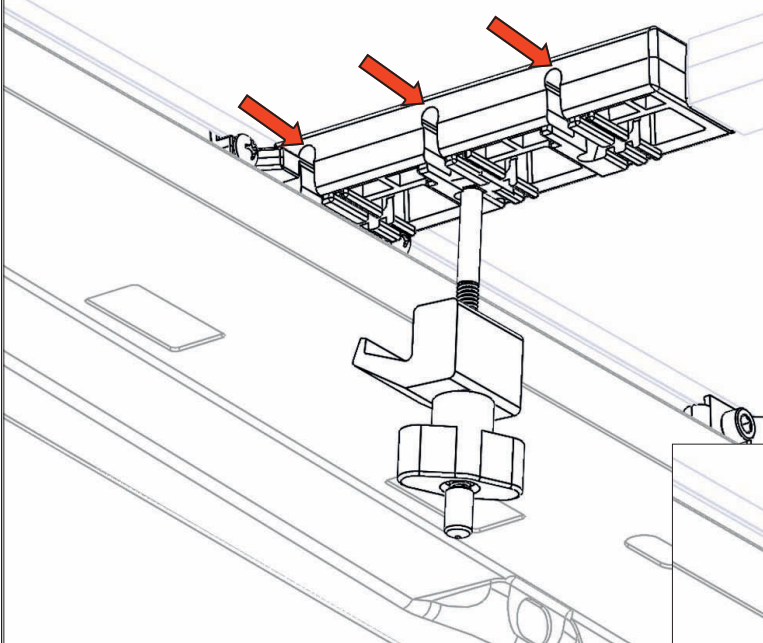

SELECT INSERT THAT BEST ALIGNS CLAMP TO SIDE OF THE BED

NOTE:
STANDARD FRONT CLAMP INSTALLTION SHOWN.
SEE INSTRUCTIONS IN CLAMP KIT FOR ASSEMBLY

CLAMP WILL SWIVEL SIDE TO SIDE

ENSURE CLAMP IS POSITIONED UNDER BED WALL FLANGE. THEN, HAND TIGHTEN UNTIL CLAMP CONTACTS THE TRUCK RAIL. TIGHTEN AN ADDITIONAL TWO TURNS.

DO NOT USE WRENCH OR OVERTIGHTEN!

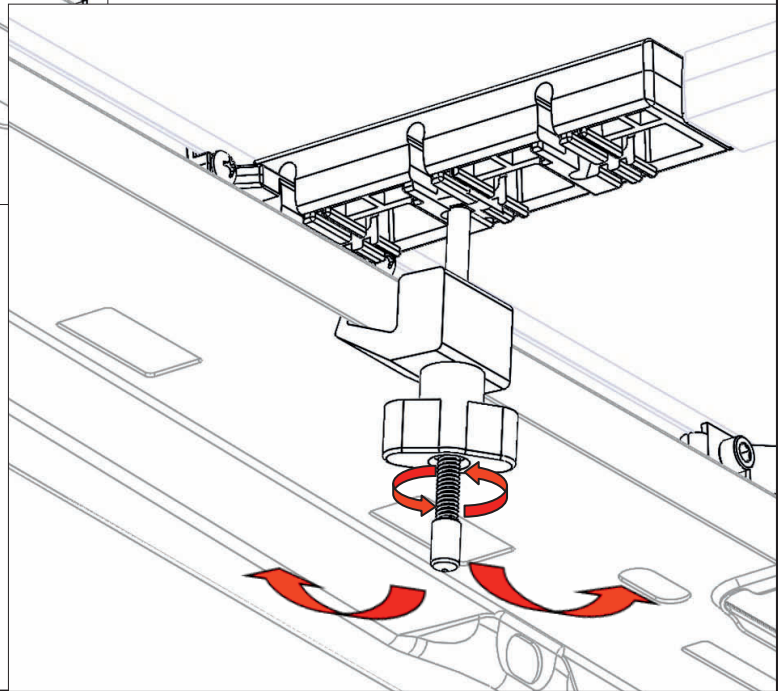

6 SECONDARY CLAMPS WITH SECURITY BUCKLES

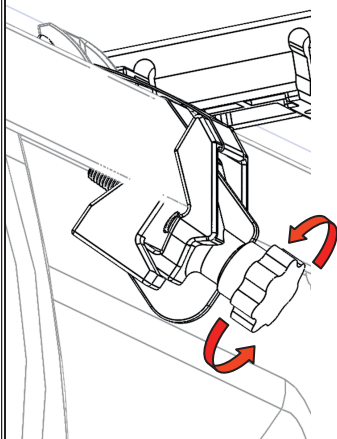

ENSURE SECONDARY CLAMP IS POSITIONED UNDER BED WALL FLANGE. HAND TIGHTEN UNTIL CLAMP CONTACTS. TIGHTEN AN ADDITIONAL TWO TURNS.

NOTE:
SHOWN WITH CLAMPS INSTALLED FOR CLARITY

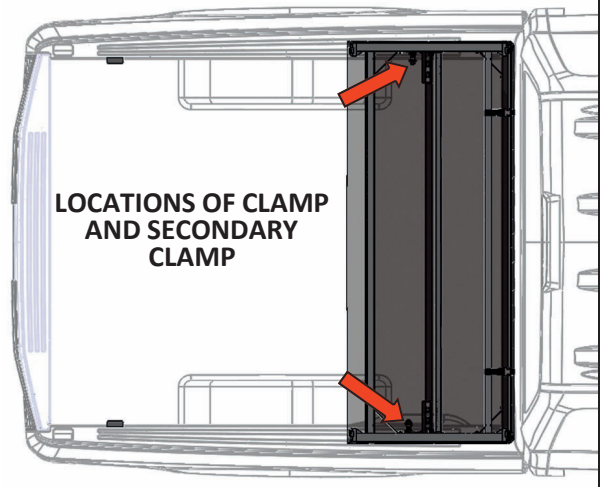

LATITUDE INSTALLATION INSTRUCTIONS

7 INSTALLING THE REAR LATCHING SYSTEM

WITH FRONT CLAMPS SECURE, COMPLETELY CLOSE THE COVER.

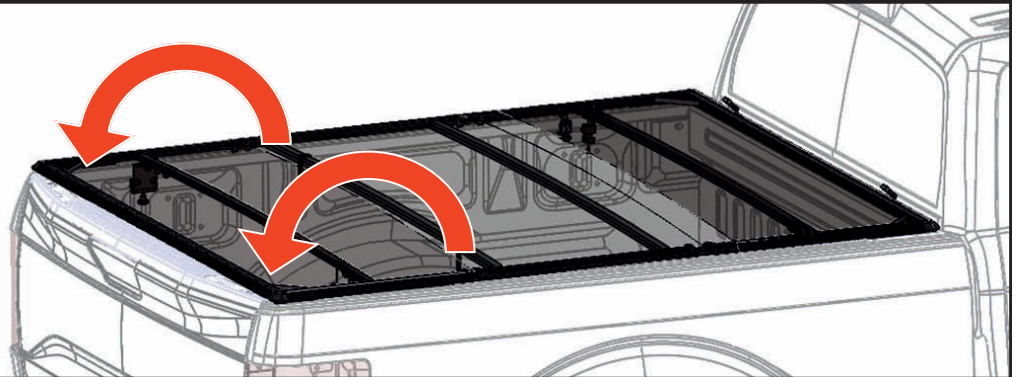

8 INSTALLING THE REAR STRIKE PLATE

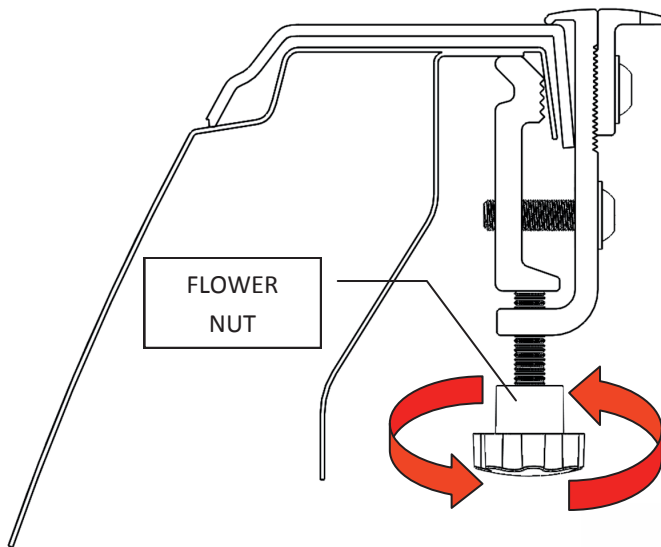

INSTALL REAR CLAMPS

STEP 1: PLACE CLAMP UNDER BED RAIL AS SHOWN. TIGHTEN FLOWER NUT AS SHOWN BY HAND UNTIL CONTACT IS MADE. (CLAMP KIT STYLES VARY)

STEP 2: TIGHTEN BOTH 5 MM ALLEN SCREWS AS SHOWN. ONCE TIGHTENED YOU MAY REMOVE THE FLOWER NUT AND KEEP IF YOU NEED TO RE-INSTALL.

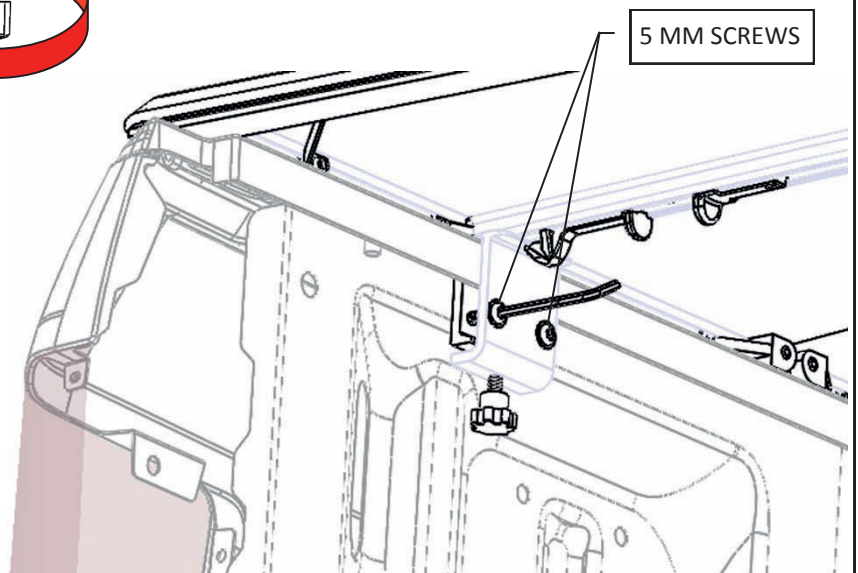

LATITUDE INSTALLATION INSTRUCTIONS

9 ADJUSTING THE STRIKE PLATE

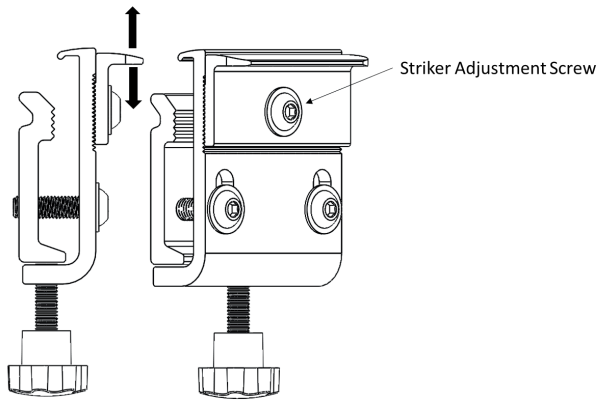

NOTE:
STRIKER MAY NEED
ADJUSTMENT AFTER SEALS
HAVE COMPRESSED PERIODICALLY CHECK .

10 ADJUSTING THE CYNC LATCH

TO ADJUST THE CYNC LATCHING SYSTEM.
ADJUST ONE SIDE AT A TIME. MAKE SURE
THE OTHER SIDE IS TIGHTENED DOWN.

1. LOOSEN BOTH SET SCREWS ON ONE SIDE.
 2. SLIDE CYNC LATCHING SYTEM CATCH TO
OVERLAP STRIKER PLATE BY 1/2".
 3. TIGHTEN LATCH GUIDE SET-SCREW.
 4. PULL INWARDS ON INNER LATCH BOTH
SIDES. UNTIL LATCH HAS TENSION.
 5. TIGHTEN INNER LATCH SET SCREW.
- * REPEAT FOR OPPOSITE SIDE.

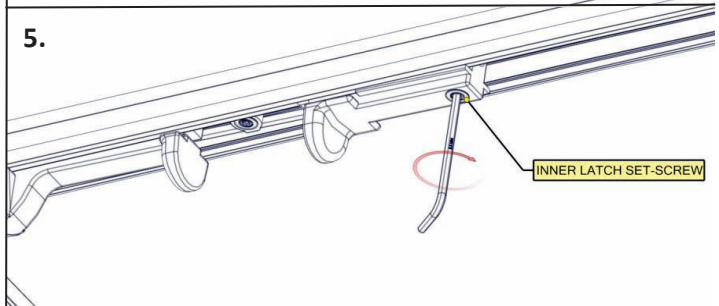
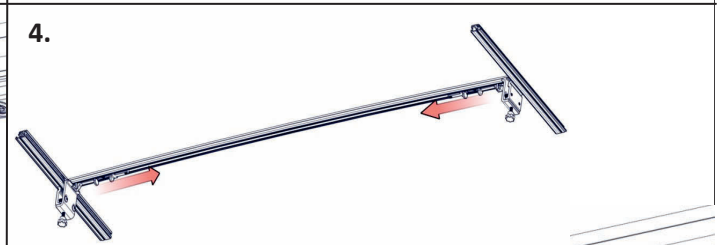
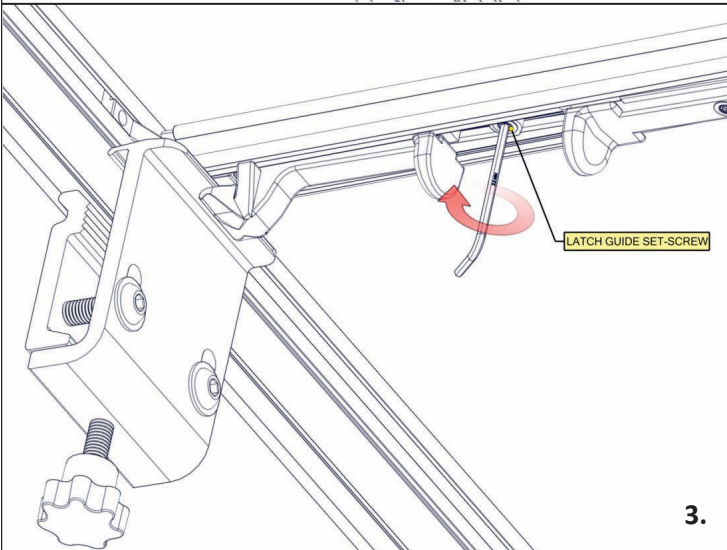
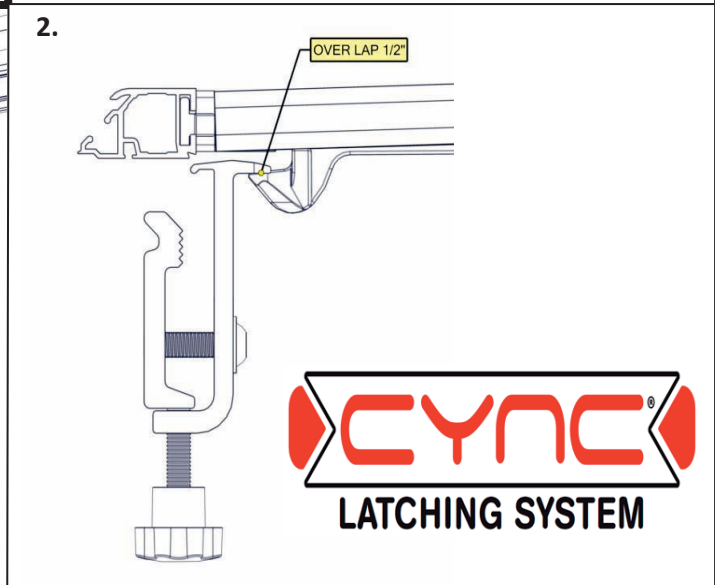
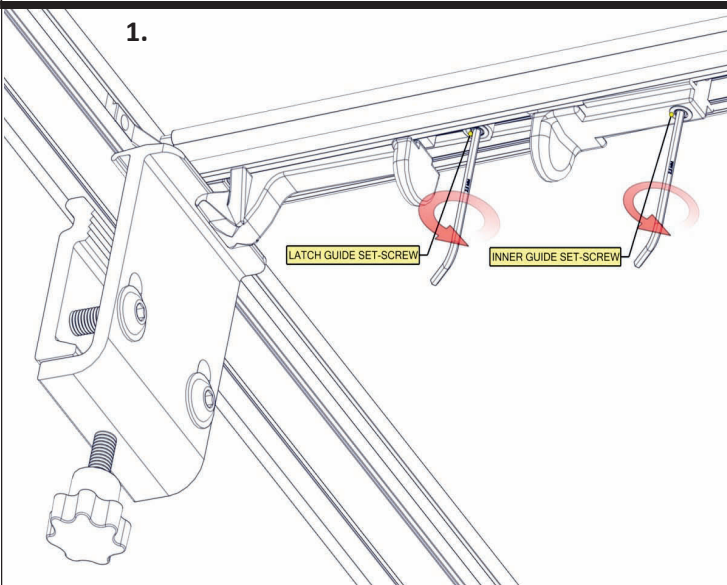

LATITUDE INSTALLATION INSTRUCTIONS

11

SECURING AN OPEN COVER FOR TRAVEL

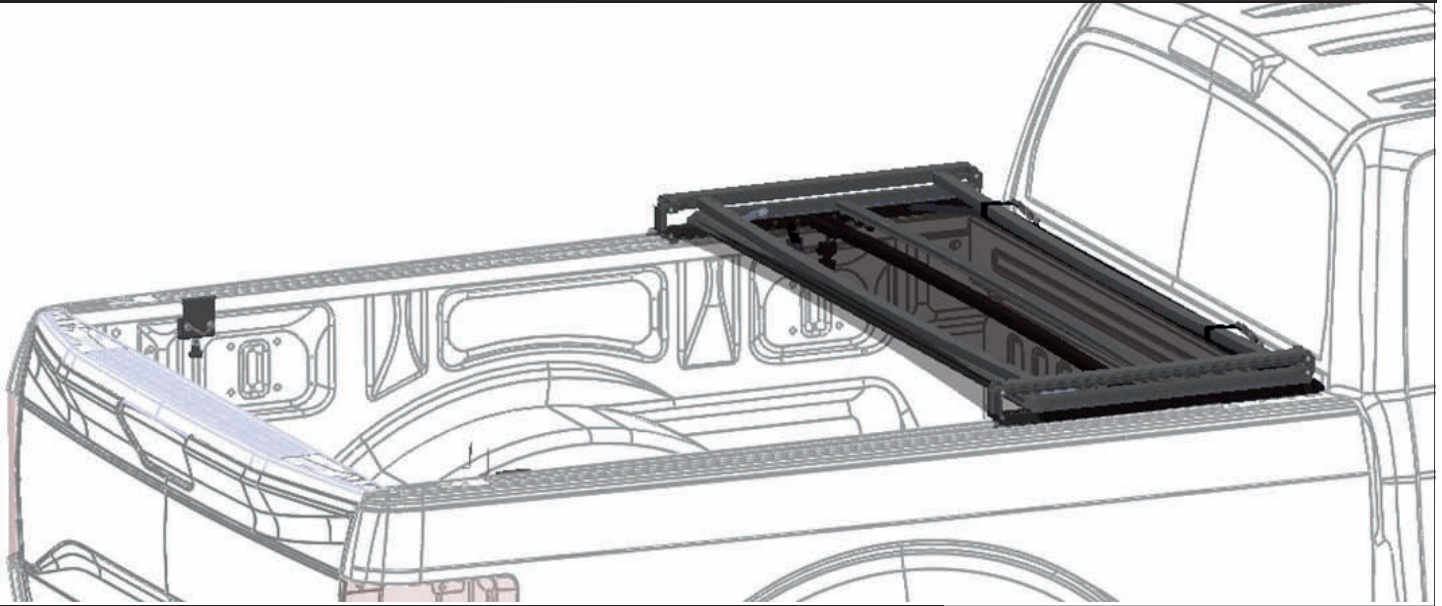

IMPORTANT NOTICE

WHILE DRIVING, COVER MUST BE COMPLETELY FLAT AND SECURED WITH ALL CLAMPS SECURELY FASTENED. DO NOT DRIVE WITH COVER IN PARTIALLY OPEN POSITION.



FOLD THE COVER FORWARD AND FASTEN BOTH STRAPS IN THE MIDDLE SECTION TO THE FRONT RAIL CLIPS.

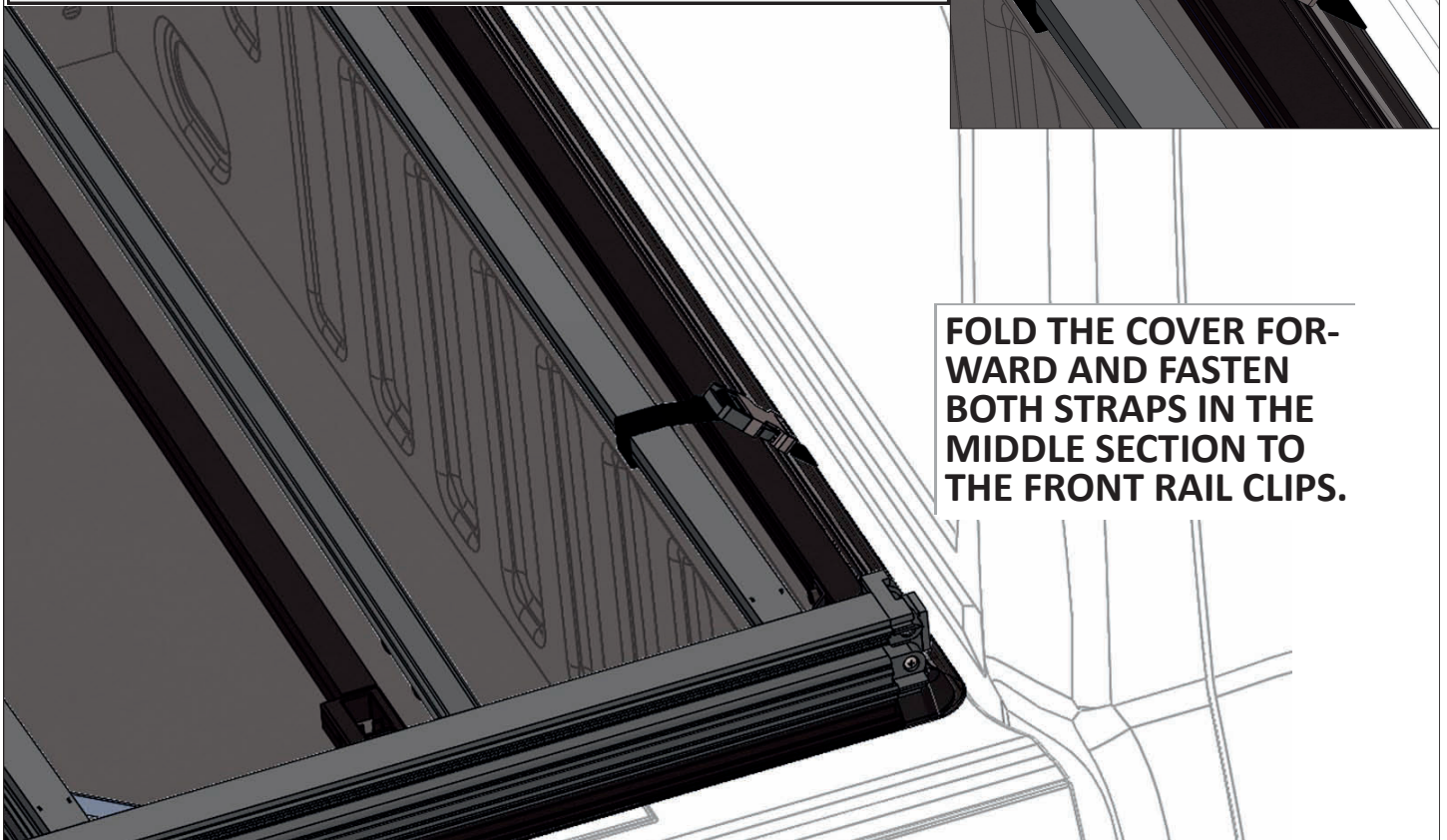

IDENTIFIER	DESCRIPTION	QUANTITY	ITEM NUMBER
A	Latitude NF13 (2013+ Nissan Frontier) Clamp Kit	1 EACH	203983
B	Latitude Angle Clamp Kit	1 EACH	204320
C	Latitude GC15 (2015+ GM Colorado/Canyon) Clamp Kit	1 EACH	204322
D	Latitude GS14 (2014+ GM Silverado/Sierra) Clamp Kit	1 EACH	204323
E	Latitude Toyota Clamp Kit	1 EACH	204324
F	Latitude NT16 (2016+ Nissan Titan) Clamp Kit	1 EACH	204325
G	CYNC Latch Kit	1 EACH	203184

A

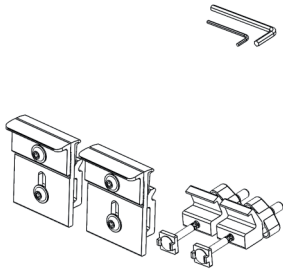

#203983

B

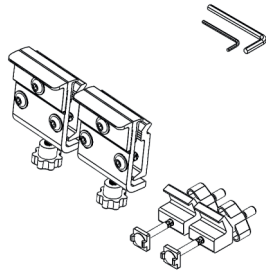

#204320

C

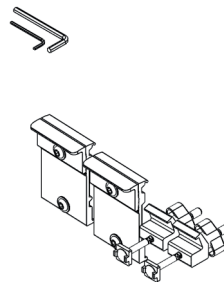

#204322

D

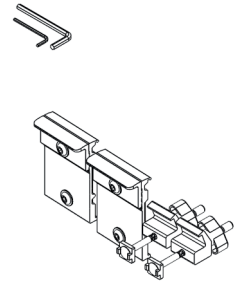

#204323

E

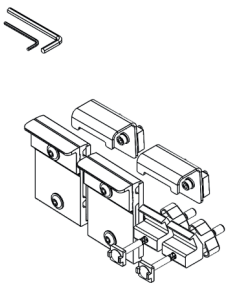

#204324

F

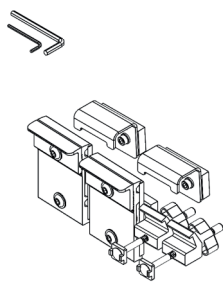

#204325

G

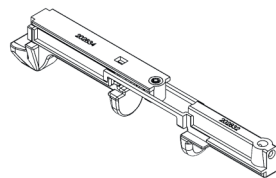

#203184

TRUCK DESCRIPTION	Clamp Kit
56FF15 2015+ Ford F150 5'6"	204320
66FF15 2015+ Ford F150 6'6"	204320
58GS14 2014+ GM Silverado/Sierra 5'8"	204323
66GS14 2014+ GM Silverado/Sierra 6'6"	204323
57DR09 2009+ Dodge Ram 5'7"	204320
64DR09 2009+ Dodge Ram 6'4"	204320
52GC15 2015+ GM Colorado/Canyon 5'2"	204322
62GC15 2015+ GM Colorado/Canyon 6'2"	204322
69FS99 1999+ Ford Super Duty 6'9"	204320
56FF04 2004-14 Ford F150 5'6"	204320
66FF04 2004-14 Ford F150 6'6"	204320
52TC16 2016+ Toyota Tacoma 5'2" w/Track	204324
62TC16 2016+ Toyota Tacoma 6'2" w/Track	204324
56TT14 2014+ Toyota Tundra 5'6" w/Track	204324
66TT14 2014+ Toyota Tundra 6'6" w/Track	204324
56TT14 2014+ Toyota Tundra 5'6" wo/Track	204320
66TT14 2014+ Toyota Tundra 6'6" wo/Track	204320
50NF13 2013+ Nissan Frontier 5' w/Track	203983
61NF13 2013+ Nissan Frontier 6'1" w/Track	203983
50NF13 2013+ Nissan Frontier 5' wo/Track	203983
61NF13 2013+ Nissan Frontier 6'1" wo/Track	203983
56NT16 2016+ Nissan Titan 5'6" w/Track	204325
66NT16 2016+ Nissan Titan 6'6" w/Track	204325
56NT16 2016+ Nissan Titan 5'6" wo/Track	204320
66NT16 2016+ Nissan Titan 6'6" wo/Track	204320

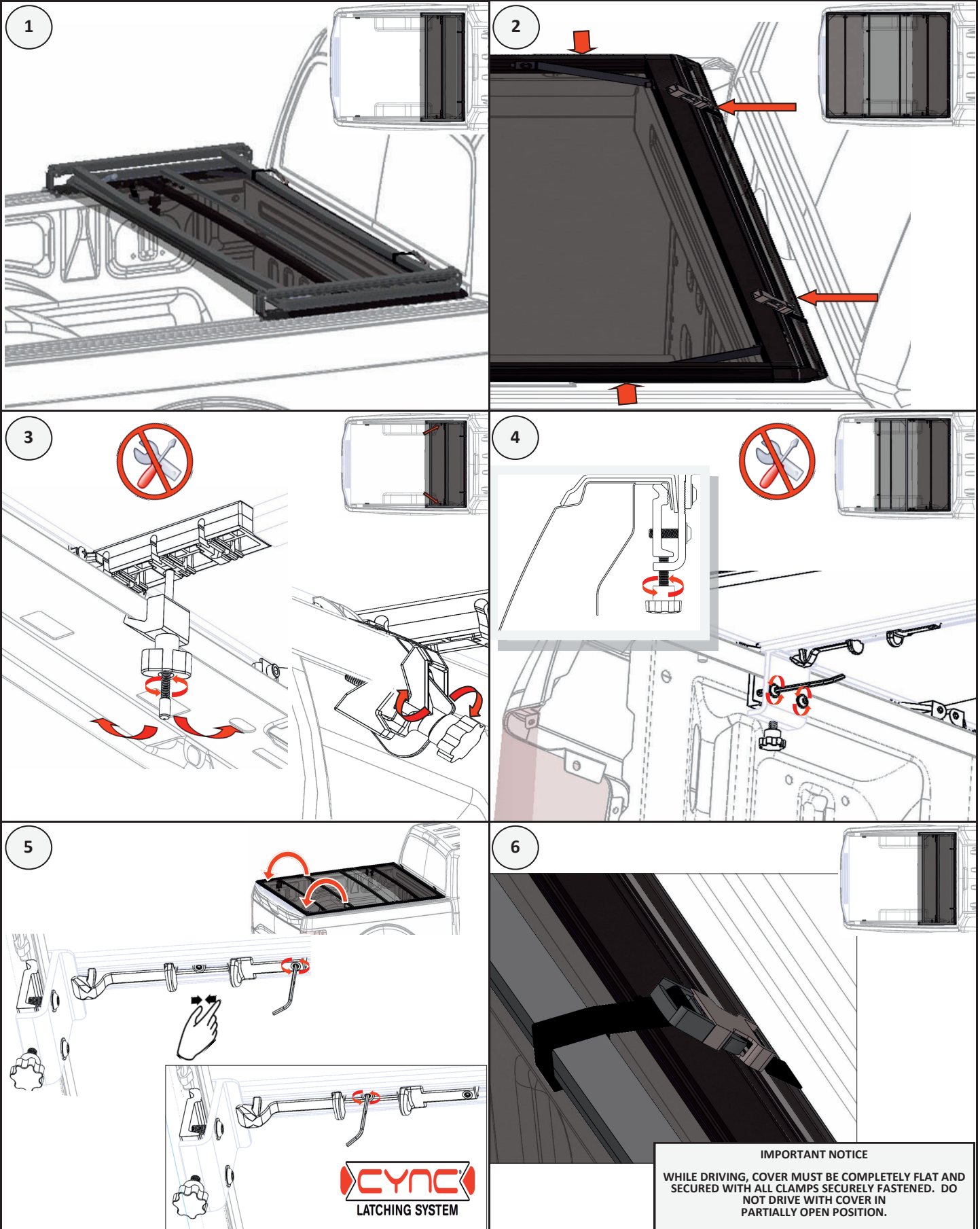



WARRANTY AND MAINTENANCE

LIMITED LIFETIME WARRANTY POLICY

COVERAGE:

LEER®, a Division of Truck Accessories Group, LLC, warrants you, the original retail purchaser, that your Latitude by LEER soft tri-fold tonneau cover is free from defects in the material and workmanship. The warranty will void if the product has been damaged by accident, neglect, abuse, inappropriate use, improper installation or acts of God. LEER may, at our sole discretion, either repair or replace products that prove to be defective.

WARRANTY PERIOD:

This warranty shall apply for Limited Lifetime as long as the Latitude soft tri-fold tonneau is in the possession of the original purchaser on original truck and a proof of purchase (original sales receipt) is submitted.

LIMITATIONS:

The above warranty shall apply only if ALL of the following conditions are met.

1. The original purchase only is covered and is not transferable.
2. The Latitude soft tri-fold tonneau cover is on the original owner's truck.
3. The Latitude soft tri-fold tonneau cover is properly installed.
4. The Latitude soft tri-fold tonneau cover has not been modified.
5. Consequential damages, including damage to cargo or truck bed, are not covered.

NOT COVERED UNDER WARRANTY:

1. Blown Off Covers:
 - A. LEER will not warranty a Latitude soft tri-fold tonneau that comes off the truck while driving or by wind.
 - B. Consumer responsibility to check clamps before driving.
2. Paint damage to your truck.
3. Damage resulting from improper or careless unpackaging. Never open packaging with box cutter or any sharp instrument as it may scratch or damage contents.
4. Damage caused by hyperextending panel hinge usually caused by hauling cargo taller than the truck bed sidewall when cover is in the "closed" position.
5. Damage caused by improper use, operation outside the products specifications, or use other than the cover's intended application.
6. Failure to install and operate equipment according to the guidelines put forth in the installation manual.
7. Damage occurring during transit provided by 3rd party shipping, example UPS or FEDEX. Claims must be filed directly with 3rd party shipper.

THIS EXPRESS LIMITED WARRANTY IS THE SOLE AND EXCLUSIVE WARRANTY PROVIDED BY TRUCK ACCESSORIES GROUP, LLC FOR THIS PRODUCT. LEER DOES NOT MAKE AND HEREBY DISCLAIMS ANY AND ALL OTHER EXPRESS OR IMPLIED WARRANTIES, INCLUDING BUT NOT LIMITED TO THE IMPLIED WARRANTY OF MERCHANTABILITY AND THE IMPLIED WARRANTY OF FITNESS FOR A PARTICULAR PURPOSE.

REPLACEMENT PARTS:

Contact your LEER Authorized Retailer for a list of replacement parts and cost.

SAFETY & CARE TIPS:

1. Take care of your equipment.
2. Periodically check your clamps for proper tension and make sure they are clamped down before traveling.
3. When you are riding with the cover in the folded open position, make sure the tie-down straps are fastened.
4. Periodic cleaning with mild soap and water only. Avoid use of abrasive pads or harsh cleaners as they can dull finish. Avoid use of chemicals and harsh fluids as they can damage hinges and seals voiding the warranty.

CLAIMS:

If you have any warranty issues, please contact your dealer for assistance.

REGISTRATION:

Registering your Latitude by LEER is an important step to ensuring you get the best possible ownership experience. At the same time, we would like to better understand how your truck fits into your life. Feedback from LEER owners helps us design products that better fit your needs.

REGISTER TODAY AT: <http://www.leer.com/Leer-warranty-survey>.