



AIRCHARGER®

HIGH-FLOW INTAKE KITS

NOT LEGAL FOR SALE OR USE ON ANY POLLUTION CONTROLLED MOTOR VEHICLE IN CALIFORNIA OR STATES ADOPTING CALIFORNIA EMISSION PROCEDURES.

See knfilters.com for CARB status on each part for a specific vehicle

INSTALLATION INSTRUCTIONS

63-1138

HARLEY DAVIDSON

SEE CATALOG OR KNFILTERS.COM FOR CURRENT APPLICATIONS

TOOLS NEEDED:

- ratchet extension
- 7/16" socket
- 3/16" allen key
- 3/8" allen key
- 9/32" allen key
- 3mm allen key
- t27 torx
- 3/8" wrench

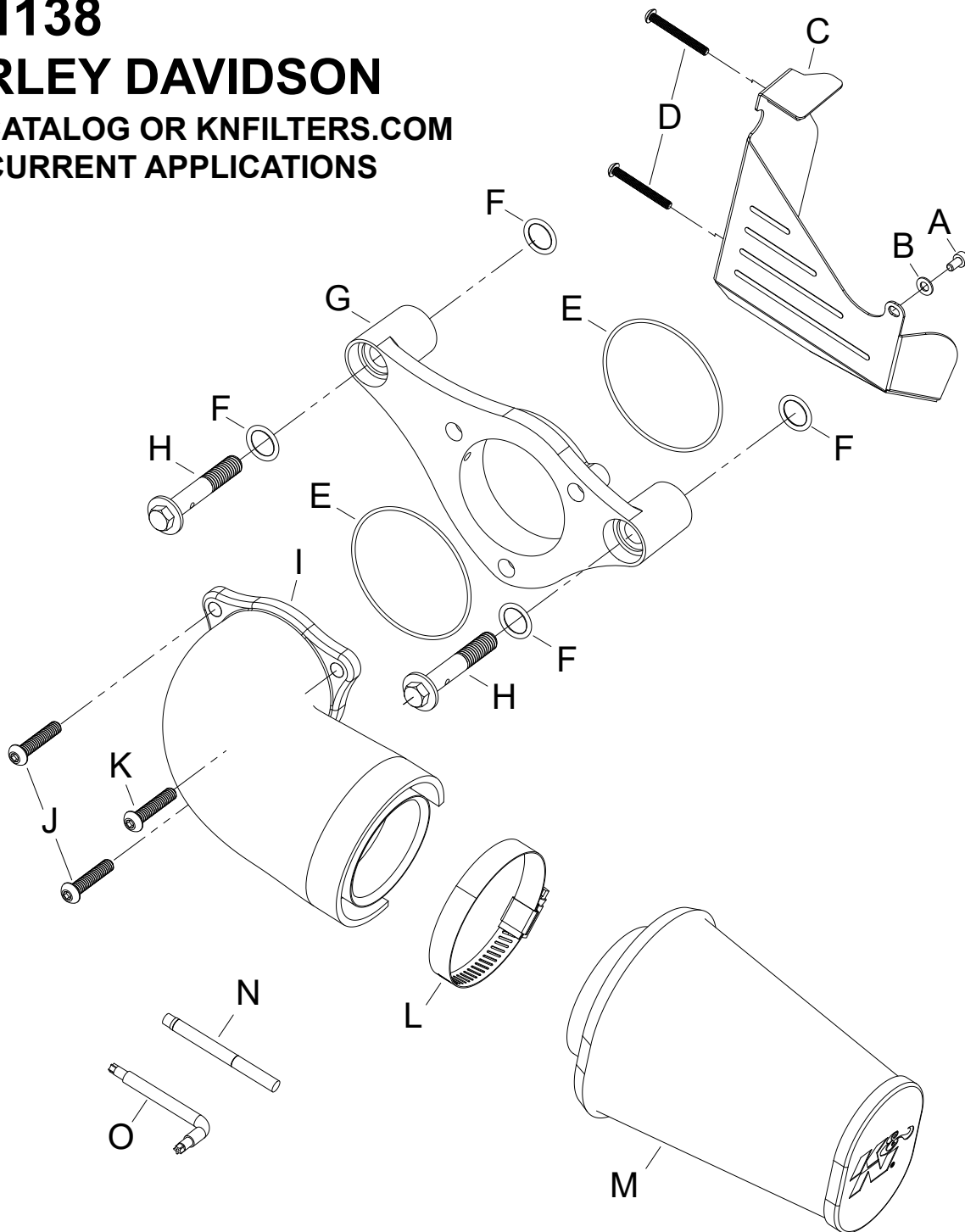

PARTS LIST:

Description	Qty.	Part #
A BOLT; 1/4-20 X 1-1/4"L	1	077011
B WASHER; 4MM FLAT	1	08278
C SERVO COVER	1	073242TK
D BOLT; 1/4-20 X 1-1/2"L, SS	2	22216
E O-RING; 2.88"OD X 2.74"ID	2	09773
F O-RING; 9/16" ID, .10 THICK	4	07761
G BACK PLATE	1	01935TK
H BOLT; BREATHER, RK-3947	2	077008
I INTAKE TUBE	1	088023TK
J BOLT; M4-0.7 X 35MM, SS, BHA	2	077012
K BOLT; M4 - 0.07 8MM, A/H CAP	1	07733
L HOSE CLAMP #40	1	08554
M FILTER CHARGER	1	RE-0960
N 2ML, MEDIUM STRENGTH	1	482
O WRENCH; TORX T20 T/R	1	69801

If you need any assistance please call 1-800-858-3333 to speak with a representative in our Customer Service Center before returning the product.

NOTE: FAILURE TO FOLLOW INSTALLATION INSTRUCTIONS AND NOT USING THE PROVIDED HARDWARE MAY DAMAGE THE INTAKE TUBE, THROTTLE BODY AND ENGINE.

TO START:

1. Turn off the ignition and disconnect the negative battery cable.

NOTE: Disconnecting the negative battery cable erases pre-programmed electronic memories. Write down all memory settings before disconnecting the negative battery cable. Some radios will require an anti-theft code to be entered after the battery is reconnected. The anti-theft code is typically supplied with your owner's manual. In the event your vehicles anti-theft code cannot be recovered, contact an authorized dealership to obtain your vehicles anti-theft code.



2. Loosen and remove the bolt which secures the decorative filter cover and remove the cover from the vehicle.



3. Remove the three bolts that secure the air filter element and then remove the air filter and crank case breather tubes.



4. Remove the two breather bolts shown and then remove the rear air filter housing from the vehicle. **NOTE: K&N Engineering, Inc., recommends that customers do not discard factory air intake.**



5. Remove the two servo cover bolts shown.



6. Install the K&N® servo cover and secure with the provided hardware to the original servo cover mounting bolt locations.



7. Install two of the breather O-rings and the throttle body O-ring into the base plate as shown.
NOTE: Use a few small dabs of grease to secure the O-rings in place while installing the base plate to the engine.



8. Using the provided throttle body mounting bolts, install the base plate onto the engine. Do not completely tighten the bolts; they are just being used to hold the base plate in the correct position at this time. Secure the servo cover to the back of the base plate with the hardware provided. Now install the remaining breather O-rings into the base plate and secure the base plate with the provided breather bolts. Then remove the three throttle body bolts.

NOTE: Apply one drop of the provided thread locker to the threads of each bolt.



9. Install the provided O-ring and tube mounting bolts into the intake tube as shown.



10. Install the intake tube onto the base plate.
NOTE: Apply one drop of the provided thread locker to the threads of each bolt.



11. Install the air filter onto the intake tube and secure with the provided hose clamp.

12. Reconnect the vehicle's negative battery cable. Double check to make sure everything is tight and properly positioned before starting the vehicle.

13. It will be necessary for all K&N® high flow intake systems to be checked periodically for realignment, clearance and tightening of all connections. Failure to follow the above instructions or proper maintenance may void warranty.

ROAD TESTING:

1. Start the engine with the transmission in neutral or park, and the parking brake engaged. Listen for air leaks or odd noises. For air leaks secure hoses and connections. For odd noises, find cause and repair before proceeding. This kit will function identically to the factory system except for being louder and much more responsive.

2. Test drive the vehicle. Listen for odd noises or rattles and fix as necessary.

3. If road test is fine, you can now enjoy the added power and performance from your kit.

4. K&N Engineering, Inc., requires cleaning the intake system's air filter element every 100,000 miles. When used in dusty or off-road environments, our filters will require cleaning more often. We recommend that you visually inspect your filter once every 25,000 miles to determine if the screen is still visible. When the screen is no longer visible some place on the filter element, it is time to clean it. To clean and re-oil, purchase our filter Recharger® service kit, part number 99-5050 or 99-5000 and follow the easy instructions.

NOT LEGAL FOR SALE OR USE ON ANY POLLUTION CONTROLLED MOTOR VEHICLE IN CALIFORNIA OR STATES ADOPTING CALIFORNIA EMISSION PROCEDURES.

See knfilters.com for CARB status on each part for a specific vehicle