



## Installation Instructions Competition Plus Shifter Assembly

Catalog# 3914076

**WORK SAFELY:** Perform this on a good clean level surface for maximum safety and with the engine turned “off”. Apply parking brake and place blocks or wedges in front of and behind both rear wheels to prevent movement in either direction.

**CAUTION:** To avoid any possibility of bodily injury or damage to vehicle, do not attempt disconnect or installation until you are confident that the vehicle is safely secured and will not move.

### IMPORTANT

The bolts that fasten the stick to the shifter and the bolts that are used as gear stops are SAE grade 5 bolts. If the bolts need to be replaced, make sure they are SAE grade 5.

**NOTE:** The stiffener plate is used with all shifters except those which have tapped holes. Both methods are shown below.

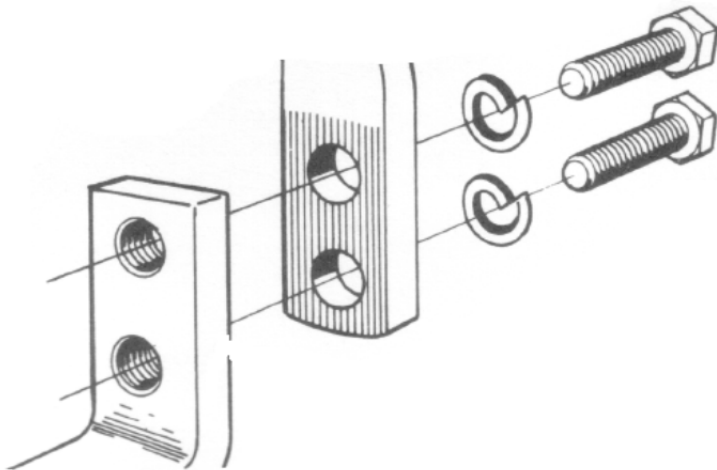

Stick bottom with tapped holes do not require stiffener plate.

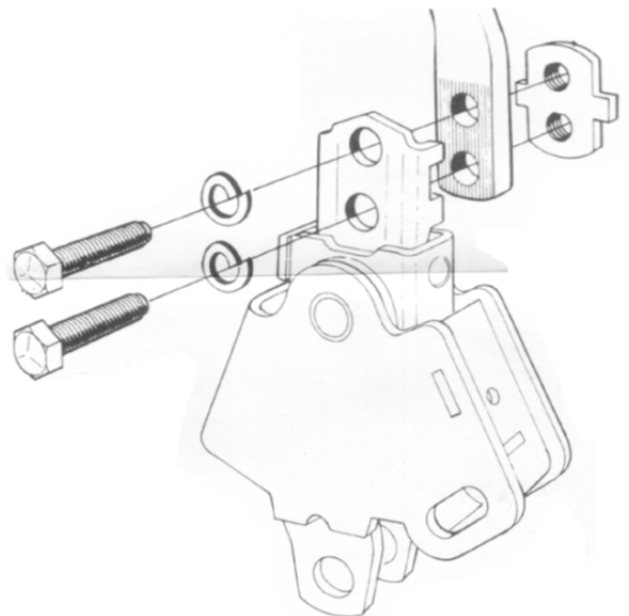

Standard stick configuration requires the use of a stiffener plate.

**Serration of stick mesh with serrations in shifter mount.**

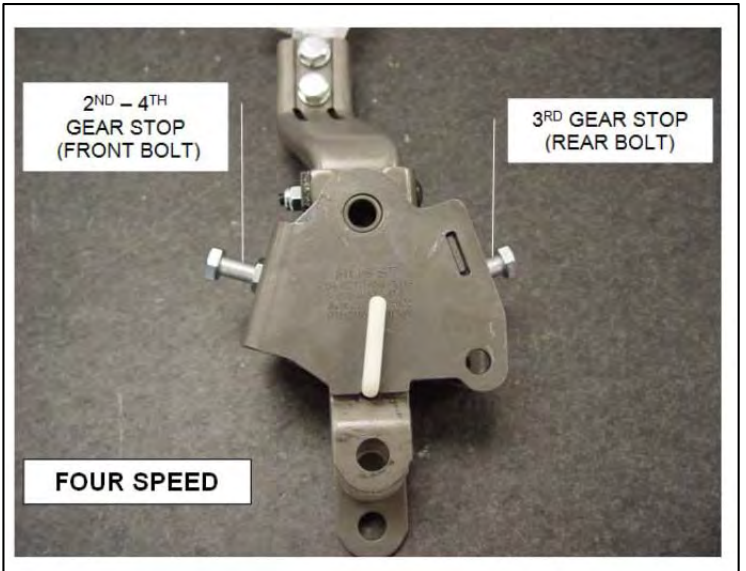
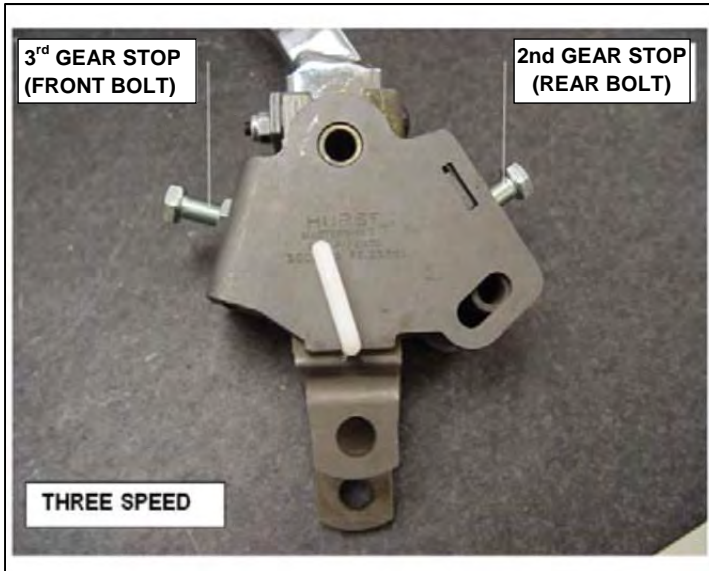

**IMPORTANT: RETAIN THESE INSTRUCTIONS FOR FUTURE REFERENCE**

### **Technical Service**

A highly trained technical service department is maintained by Hurst Performance to answer your technical questions, provide additional product information and offer various recommendations.

Hurst offers a wide variety of custom T-Handles and knobs that can be used with this shifter to allow the driver to tailor the vehicle to his/hers personal liking. See your local retailer of Hurst products for specific prices.

Technical service calls, correspondence, and warranty questions should be directed to:



**Hurst Performance Products**

(707) 544-4761

[www.Hurst-Shifters.com](http://www.Hurst-Shifters.com)