

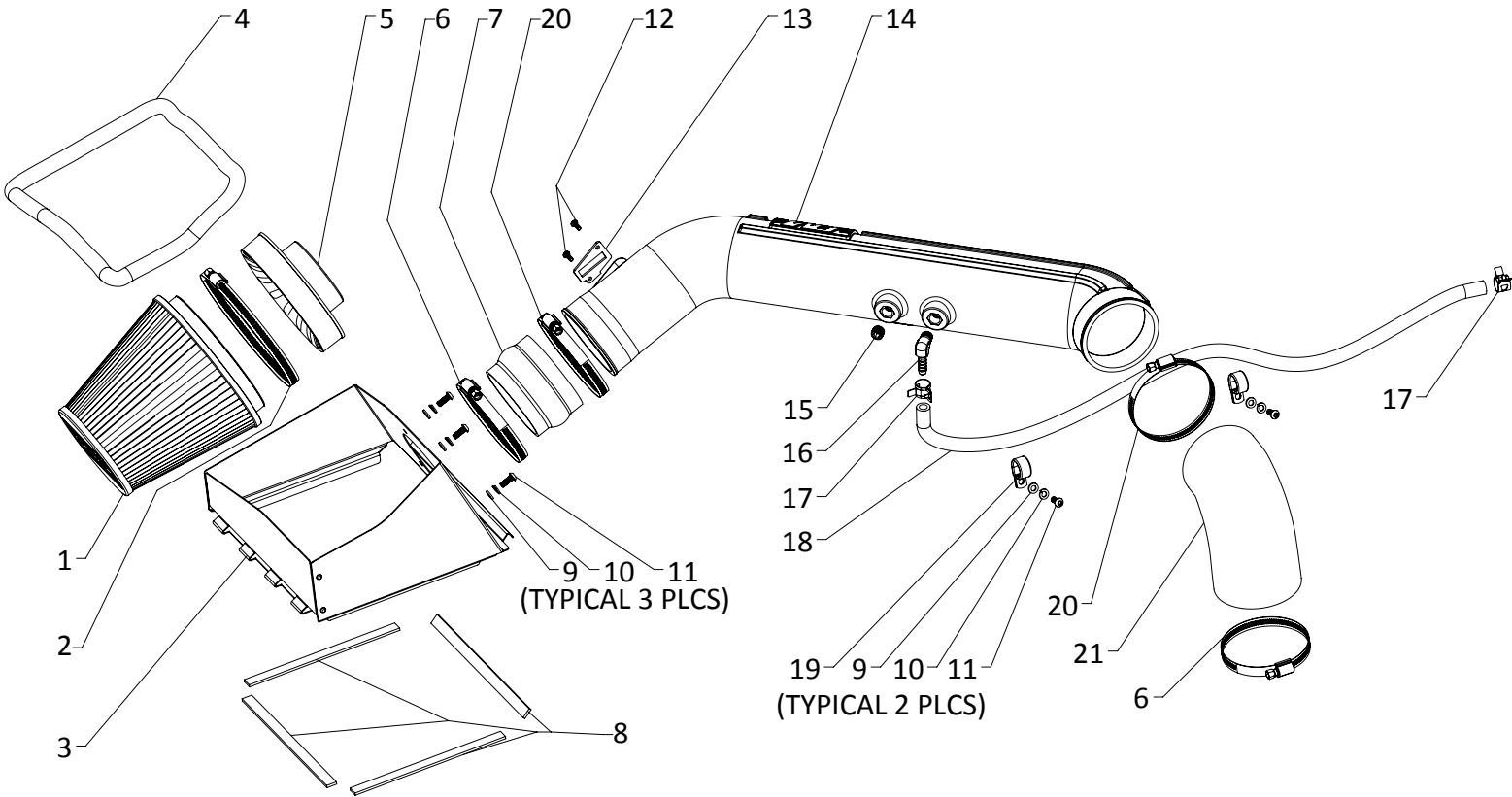

Installation Instructions for SYSTEM # 615125

2007-14 Lincoln Navigator
 2007-14 Ford Expedition
 2009-10 Ford F-150
 5.4L V8 Engine

NOT LEGAL FOR SALE OR USE ON ANY POLLUTION-CONTROLLED MOTOR VEHICLE IN CALIFORNIA OR IN STATES THAT HAVE ADOPTED CALIFORNIA EMISSION PROCEDURES.



ITEM NO.	PART NUMBER	DESCRIPTION	QTY.
1	AF1002	AIR FILTER, 7-1/2" x 6" DIA	1
2		CLAMP, SCREW, #104 (4-1/8" - 7")	1
3	AF3018	HEAT SHIELD, 07-14 NAVIGATOR & EXPEDITION, 09-10 F-150, 5.4L	1
4	49000061	GASKET, HEAT SHIELD	48"
5	AF6001	ADAPTER, AIR FILTER 3-1/2" x 6"	1
6	MC350H	CLAMP, SCREW, #56 (3-1/16" - 4")	2
7	AF4069	COUPLER, FLEX 3-3/4" I.D. - 3-1/2" I.D. x 2-1/2" L	1
8	49000067	SEAL STRIP, ADHESIVE, 1/8" x 1/2"	48"
9	HW319	FLAT WASHER, M6	5
10	HW318	LOCK WASHER, M6	5
11	HW244	SCREW, M6 x 1.0 x 16MM	5

ITEM NO.	PART NUMBER	DESCRIPTION	QTY.
12	HW248	SCREW, M4 x 0.7 x 12MM	2
13	GA139	GASKET, MAF SENSOR	1
14	AF2067	INTAKE TUBE, 07-14 NAVIGATOR & EXPEDITION, 09-10 F-150, 5.4L	1
15	AF4033	PLUG, 1/4" NPT	1
16	AF4039	ELBOW, 90°, 3/8" BARB TO 1/4" NPT MALE	1
17	MC002P	CLAMP, PINCH, 3/8" HOSE	2
18	49000065	HOSE, 3/8" I.D.	30"
19	HW529	CLAMP, CUSHIONED LOOP, 3/4" I.D. x 1/2" W	2
20	MC400H	CLAMP, SCREW, #64 (3-9/16" - 4-1/2")	2
21	AF4071	COUPLER, 90°, 3-3/4" I.D. x 3-1/2" I.D.	1
22			

REVIEW THE INSTRUCTIONS AND VERIFY THE KIT CONTENTS:

1. Please take a moment to read and understand these instructions before installing your Flowmaster performance air intake kit.



2. Use the parts drawing and list (front page) to verify your kit's contents.

In the unlikely event that any parts are missing, please contact FLOWMASTER Technical Support for replacements.

REMOVE THE FACTORY AIR INTAKE SYSTEM:

NOTES

- We highly recommend that you retain all factory air intake system parts.
- Please refer to vehicle manufacturer's recommendations regarding removal of factory components.
- Disconnecting the negative battery cable erases pre-programmed electronic memories. Write down all memory settings before disconnecting the negative battery cable. Some radios will require an anti-theft code to be entered after the battery is reconnected. The anti-theft code is typically supplied with your owner's manual. In the event your vehicle's anti-theft code cannot be recovered, contact an authorized dealership to obtain your vehicle's anti-theft code.

3. Turn off the vehicle's ignition and disconnect the negative battery cable.

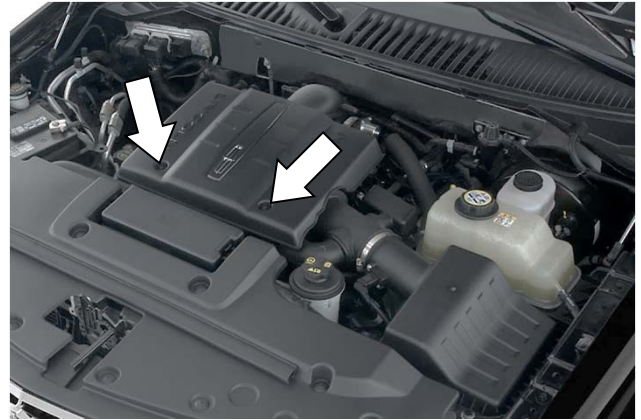

4. If your vehicle has an engine appearance cover, remove the two fasteners securing it to the engine, then remove the cover from the vehicle.

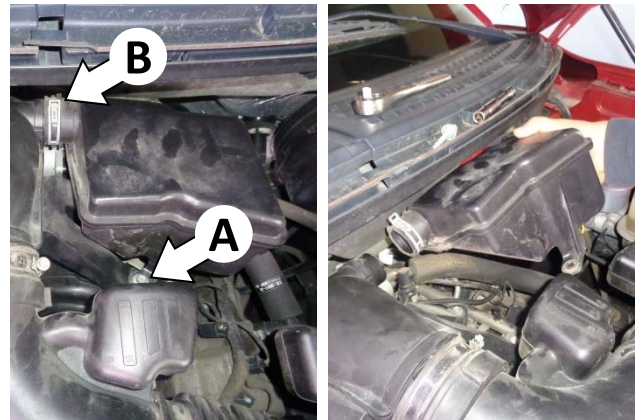

5. Remove the bolt (A) in front of the resonator. Then loosen the pinch clamp (B) with a pair of pliers, and remove the resonator from the vehicle.

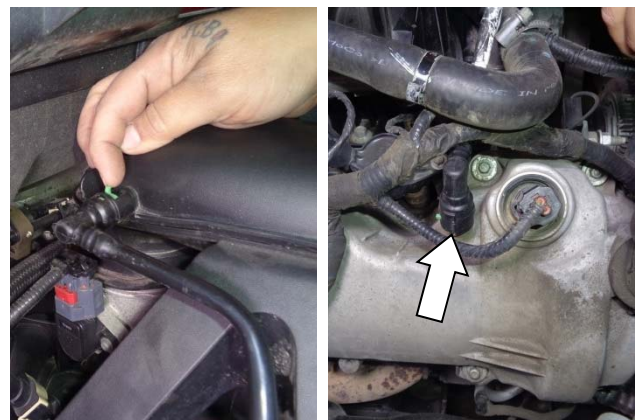

6. Release the fittings at both ends of the PCV tube by releasing their locking tabs, then remove the tube from the vehicle.



7. Disconnect the mass airflow (MAF) sensor plug by pulling its locking tab away from the sensor until it stops, then squeezing the top and bottom of plug and pulling it straight off the sensor.



8. Release the three airbox cover latches.

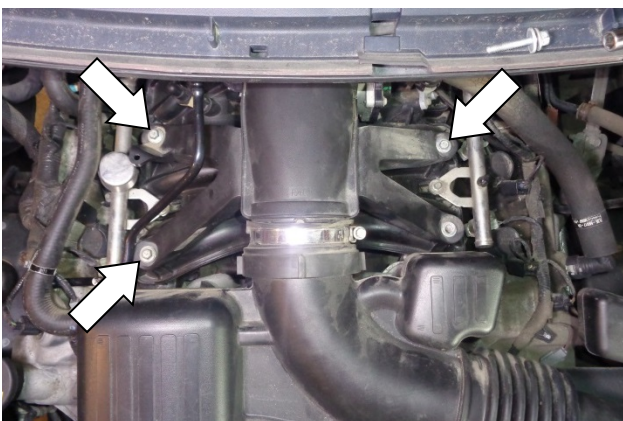

9. Remove the three intake duct bolts.



10. Separate the intake duct from the throttle body. Lift the duct up, separate the airbox cover from the airbox, and remove the assembled duct and cover from the vehicle.



11. Remove the stock air filter.



12. Remove the MAF sensor from the airbox cover, then remove the factory gasket from the sensor. **CAUTION: The sensor is delicate!** Handle it with care, and put it in a safe place until reinstallation.

ASSEMBLE AND INSTALL YOUR FLOWMASTER PERFORMANCE AIR INTAKE SYSTEM:

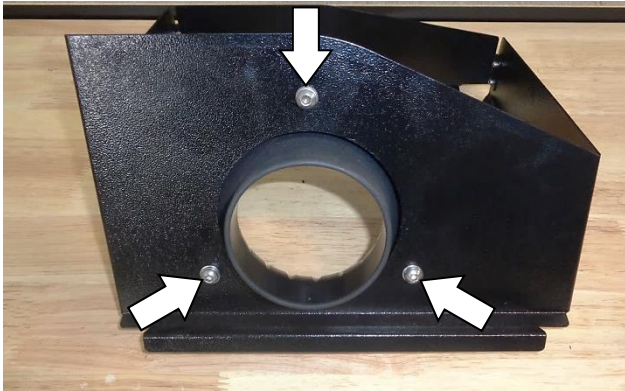

13. Assemble the air filter adapter (5) to the heat shield (3) using M6 screws (11), lock washers (10) and flat washers (9).



14. Firmly press the gasket (4) onto the edge of the heat shield, gradually working your way around. When you return to the starting point, use metal-cutting shears to trim the gasket to length.

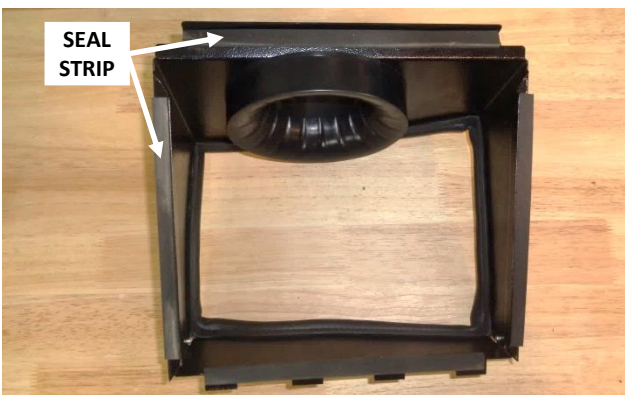

15. Cut the adhesive seal strip (8) to the lengths required, and apply it to the four bottom edges of the heat shield.



16. Slip screw clamp (2) onto the air filter (1), install the filter on the filter adapter, and tighten the clamp.

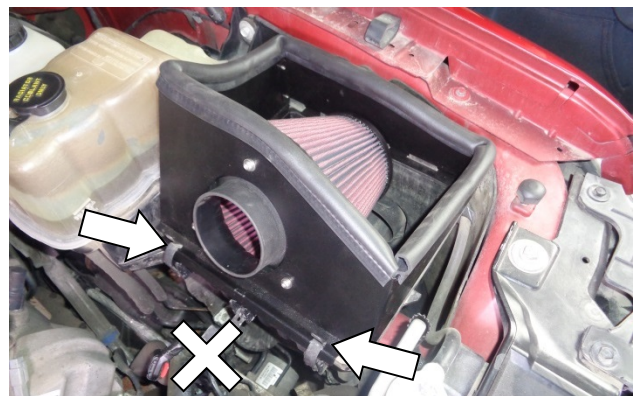

17. Insert the heat shield's four tabs into the matching slots on the lower airbox, then secure the heat shield using the two outer airbox cover latches. **NOTE: The center latch is not used.**



18. Slip a #56 screw clamp (6) onto the small end of the straight coupler (7), and install the coupler on the filter adapter. Push the coupler up against the heat shield and tighten the clamp. Then slip a #64 screw clamp (20) over the other end of the coupler.

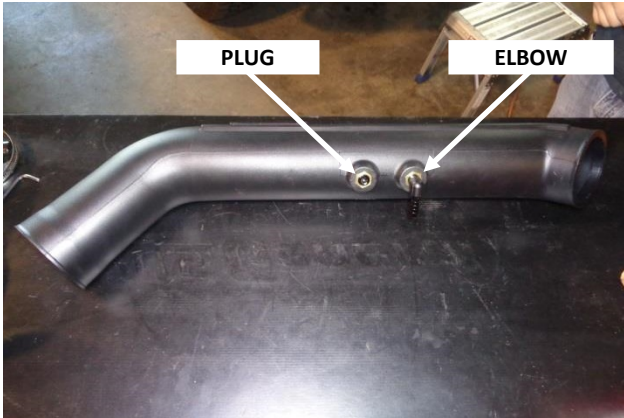

19. Apply 2 wraps of nylon thread tape to threads of the plug (15) and elbow (16), and install them in the intake tube (14) at the locations shown, with the elbow pointed down.



20. Install the MAF sensor gasket (13) over the sensor, then install the sensor in the intake tube, ensuring the correct orientation of the gasket and sensor to the mount pad. Secure the sensor using M4 screws (12).



21. Slip the second #64 screw clamp (20) over the large end of the elbow coupler (21), install the coupler on the discharge end of the intake tube, and snug (do not tighten) the clamp. Then slip the second #56 screw clamp (6) over the other end of the coupler.



22. Install the intake tube between the heat shield and throttle body.

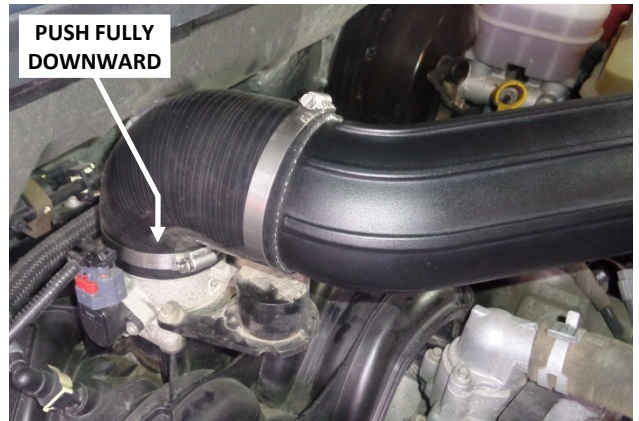

23. Push the elbow coupler down against the stops on the throttle body, then tighten only the throttle body clamp.



24. Center the intake tube between the couplers, then tighten the two tube clamps.



25. Reconnect the MAF sensor plug to the sensor, push the locking tab toward the sensor, and verify the connection is secure.

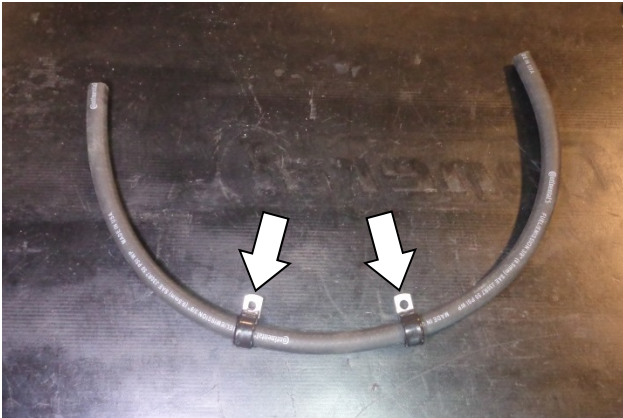

26. Slip two cushioned loop clamps (19) over the 3/8" I.D. hose (18), with their mount feet facing the same direction.

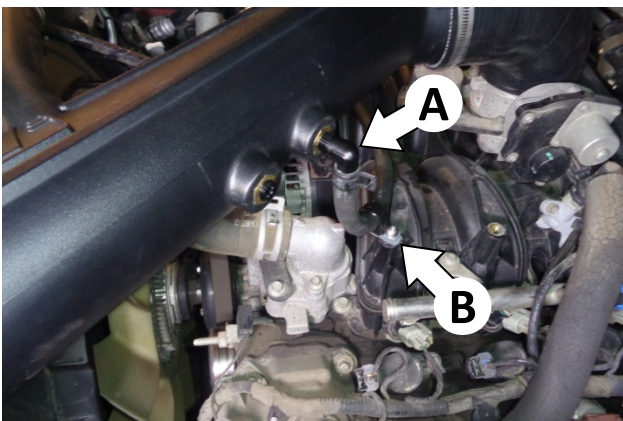

27. Secure one end of the hose to elbow (A) with a pinch clamp (17). Then attach the cushioned loop (B) clamp to the threaded insert on top of the intake manifold using an M6 screw (11), lock washer (10) and flat washer (9). **Leave the screw loose; do not tighten it at this time.**

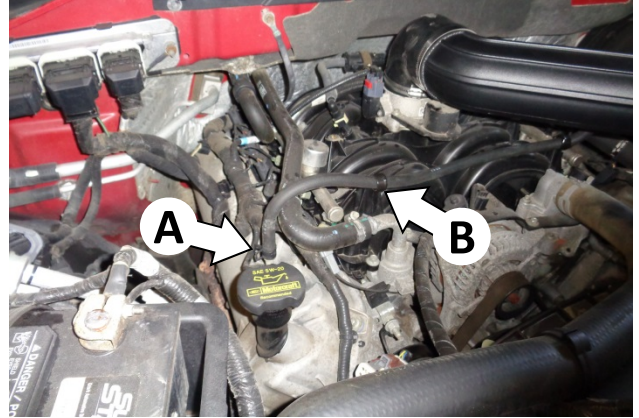

28. If required, cut the hose so that it reaches the PCV fitting (A) while avoiding contact with nearby components, and secure the hose to the fitting with a pinch clamp (17). Then secure the cushioned loop clamp (B) to the threaded insert on the intake manifold using an M6 screw (11), lock washer (10) and flat washer (9). Adjust the hose routing as required, then tighten both clamp screws.



Congratulations, the installation of your FLOWMASTER performance air intake kit is now complete!

FILTER MAINTENANCE:

We recommend that you clean and oil your air filter at 25,000 mile intervals using **Flowmaster's Filter Refresh Kit (PN 615001)**. See our website or your Flowmaster distributor for details.

IMPORTANT: RETAIN THESE INSTRUCTIONS FOR FUTURE REFERENCE

Flowmaster maintains a highly-trained technical service department to answer your technical questions, provide additional product information and offer various recommendations.

Direct all correspondence and warranty questions to:

Flowmaster
100 Stony Point Rd., Suite 125
Santa Rosa, CA 95401

Flowmaster Technical Service: (707) 544-4761
Monday – Friday: 7:30 am to 5:00 pm Pacific Time
(Closed Saturday and Sunday)

