

INSTALLATION INSTRUCTIONS

VEHICLE

MITSUBISHI MONTERO SPORT

EQUIPMENT REQUIRED:

WIRING ACCESS LOCATION: SUV1, SUV2

DRILL BITS: NONE

HITCH REQUIRES 5/8" PIN AND CLIP IF STABILIZING PIN IS NOT INSTALLED.

WRENCHES: (TIGHTEN ALL FASTENERS WITH TORQUE WRENCH) 17mm

DO NOT EXCEED LOWER OF
TOWING VEHICLE MFR'S RATINGS OR

HITCH TYPE ▼	MAX GROSS TRLR WT(LB)	MAX TONGUE WT(LB)
WEIGHT DISTRIBUTING	5500	550
WEIGHT CARRYING BALL MOUNT	5000	500

Accessory Rating

C

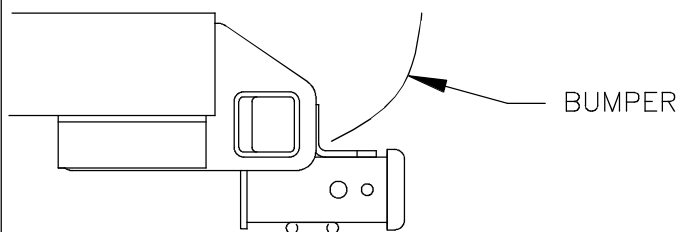

HITCH SHOWN IN PROPER POSITION

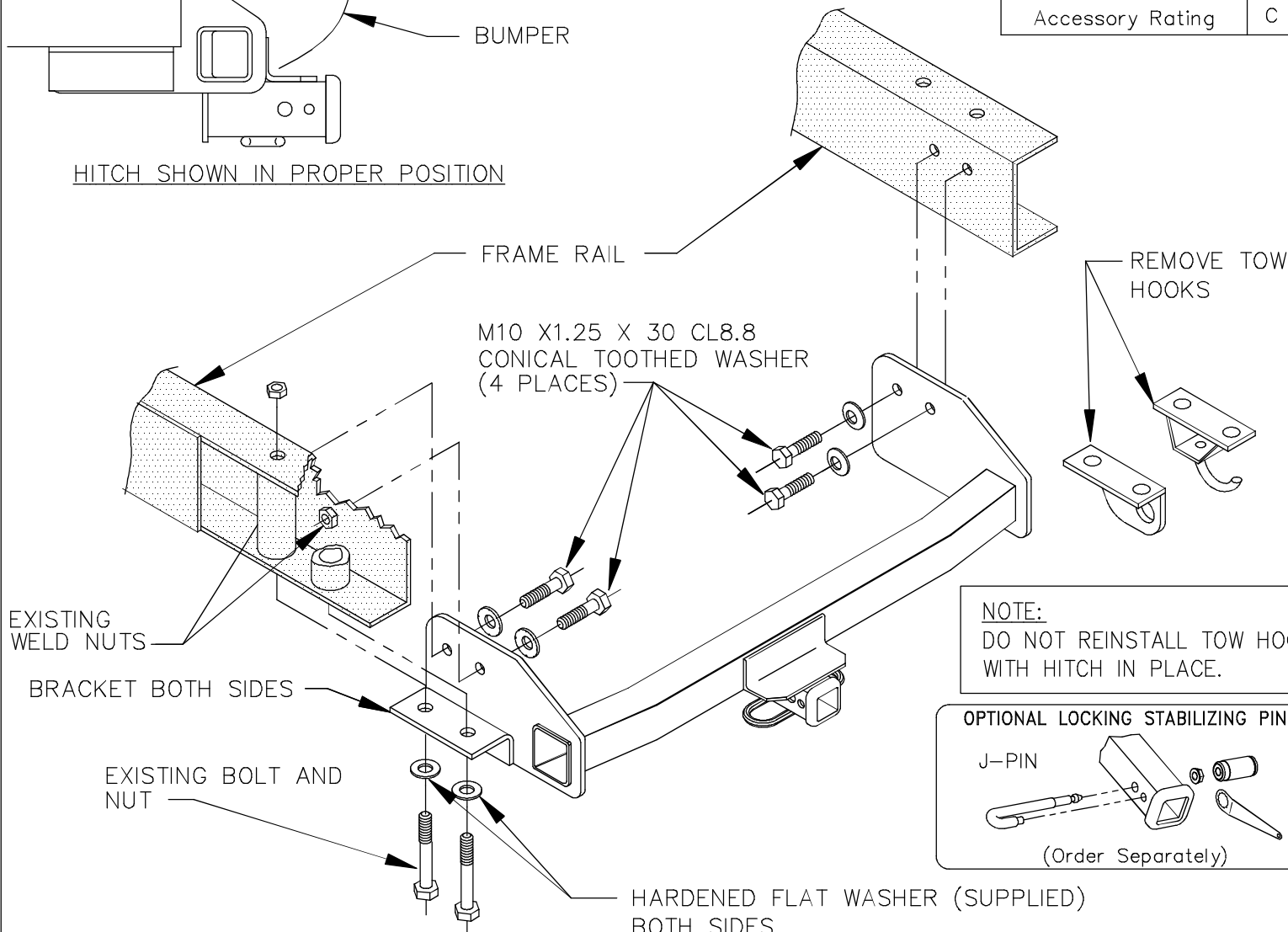

1. LOWER UNDER VEHICLE SPARE TIRE.
2. REMOVE TOW HOOKS FROM DRIVER AND PASSENGER SIDE FRAME RAILS.
3. RETURN TOW HOOKS AND LOCK WASHERS TO VEHICLE OWNER FOR REINSTALLATION IF HITCH IS REMOVED.
4. RAISE HITCH INTO POSITION AND INSTALL FASTENERS AS SHOWN ABOVE.
(DO NOT REINSTALL TOW HOOKS WITH HITCH IN PLACE.)
5. RAISE SPARE TIRE AND CHECK CLEARANCE WITH ALL VEHICLE COMPONENTS. WHEN RAISING SPARE TIRE BACK INTO POSITION, THE REAR EDGE OF THE TIRE SHOULD BE BROUGHT UP FIRST TO FIT BETWEEN THE HITCH CROSSTUBE AND THE VEHICLE BUMPER.

TIGHTEN ALL M10 BOLTS TO 38 LB-FT. TIGHTEN ALL EXISTING VEHICLE BOLTS TO 68 LB-FT.

THIS PRODUCT COMPLIES WITH SAFETY SPECIFICATIONS AND REQUIREMENTS FOR CONNECTING DEVICES AND TOWING SYSTEMS OF THE STATE OF NEW YORK, V.E.S.C. REGULATION V-5 AND SAE J684.

APPROX WEIGHT (LB.)

34

FASTENER KIT

01130-998

NOTE: Check hitch frequently, making sure all fasteners and ball are properly tightened. If hitch is removed, plug all holes in trunk pan or other body panels to prevent entry of water and exhaust fumes. A hitch or ball which has been damaged should be removed and replaced. Observe safety precautions when working beneath a vehicle and wear eye protection. Follow car maker's specs for maximum trailer weight and tongue weight. Do not cut access or attachment holes with a torch.



CEQUENT
PERFORMANCE PRODUCTS
Plymouth, Michigan

Printed in Mexico