

YEARS: 2009-PRESENT

MAKE: DODGE

MODEL: JOURNEY (INCLUDING CROSSROAD)

STYLE: CROSSOVER

WARNING: NEVER EXCEED YOUR VEHICLE MANUFACTURER'S RECOMMENDED TOWING CAPACITY

WEIGHT CARRYING:
TRAILER WEIGHT: 3,500 LBS.
TONGUE WEIGHT: 350 LBS.

WARNING:
WE RECOMMEND THE USE OF 18050 STABILIZING STRAPS FOR ALL NON-TRAILER (WHEEL-LESS) LOADS. PLEASE SEE THE CURT CATALOG OR VISIT US ONLINE AT WWW.CURTMFG.COM FOR FURTHER INFORMATION.

PRO INSTALL TIME: 30 MIN.
NOVICE INSTALL TIME: 60 MIN.

IF YOU ARE HESITANT TO UNDERTAKE THIS TASK ON YOUR OWN, CONTACT AN AUTHORIZED CURT INSTALLER FOR ADDITIONAL ASSISTANCE.

INSTALLATION TIPS:

- BEFORE YOU BEGIN INSTALLATION, READ ALL INSTRUCTIONS THOROUGHLY.
- TO EASE INSTALLATION, 2 PEOPLE MAY BE REQUIRED.
- USING PROPER TOOLS WILL GREATLY IMPROVE THE QUALITY OF THE INSTALL AND REDUCE THE TIME REQUIRED.
- NEED HELP OR HAVE SOME QUESTIONS? CALL TECHNICAL SUPPORT AT 800.798.0813



INSTALLATION REQUIRES:

SAFETY GLASSES	PRY BAR	SPRAY LUBRICANT
RATCHET	3/4" SOCKET	6" SOCKET EXTENSION
JACK STANDS	TORQUE WRENCH	

LEVEL OF DIFFICULTY: EASY

EASY	MODERATE	CHALLENGING
	TEMPORARILY LOWER EXHAUST	
	FISHWIRE HARDWARE	
	NO DRILLING REQUIRED	

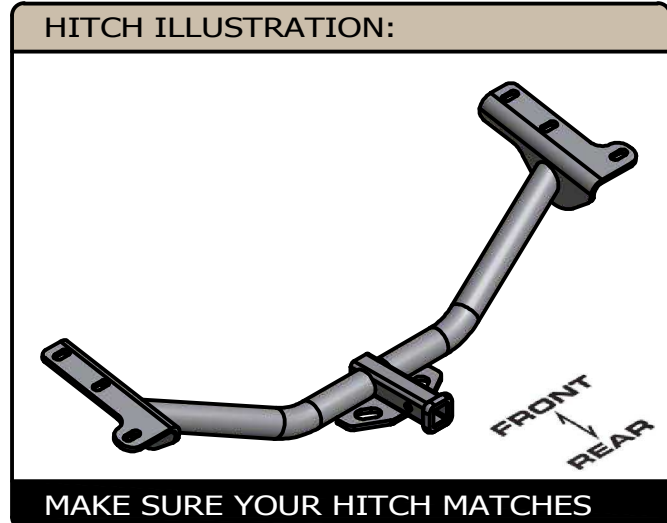

PERIODICALLY CHECK THIS RECEIVER HITCH TO ENSURE ALL FASTENERS ARE TIGHT AND ALL STRUCTURAL COMPONENTS ARE SOUND

CURT Manufacturing LLC. warrants this product to be free of defects in material and/or workmanship at the time of retail purchase by the original purchaser. If the product is found to be defective, CURT Manufacturing LLC. may repair or replace the product at their option, when the product is returned, prepaid, with proof of purchase. Alteration to, misuse of, or improper installation of this product voids the warranty. CURT Manufacturing LLC.'s liability is limited to repair or replacement of products found to be defective, and specifically excludes liability for incidental or consequential loss or damage. For more information log onto www.curtmfg.com, & for helpful towing tips log onto www.hitchinfo.com

11/17/2014

INSTALLATION WALKTHROUGH:

Parts List			
ITEM	QTY	PART NUMBER	DESCRIPTION
1	2	CM-SP4	.250 x 1.50 x 3.00" SQUARE HOLE SPACER
2	6	HFN 1213	HEX FLANGE NUT
3	2	1_2 FISHWIRE	1/2" FISHWIRE
4	4	CM-SP12	.250 x 1.00 x 2.00" SQUARE HOLE SPACER
5	2	CM-SP38	1/2" WEDGE SPACER
6	6	1/2-13 x 1 1/2	CARRIAGE BOLT

FISHWIRE TECHNIQUE

INSERT COILED END OF FISHWIRE TOOL THROUGH HITCH MOUNTING HOLE IN VEHICLE FRAME RAIL AND OUT THE ACCESS HOLE. PASS COILED END OF FISHWIRE THROUGH SPACER AND THREAD BOLT INTO COIL. KINK WIRE TO KEEP SPACER SEPERATE FROM BOLT AS SHOWN. PULL FISHWIRE, SPACER, AND BOLT THROUGH FRAME AND OUT MOUNTING HOLE. USE FISHWIRE TO GUIDE HITCH DURING MOUNTING AND PREVENT LOSS OF BOLT / SPACER INSIDE FRAME RAIL.

NOTE: SOME VEHICLES MAY FISHWIRE THROUGH END OF FRAME

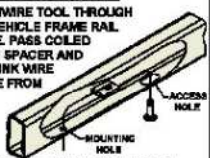

PASSENGER SIDE FRAME RAIL

DRIVER SIDE FRAME RAIL

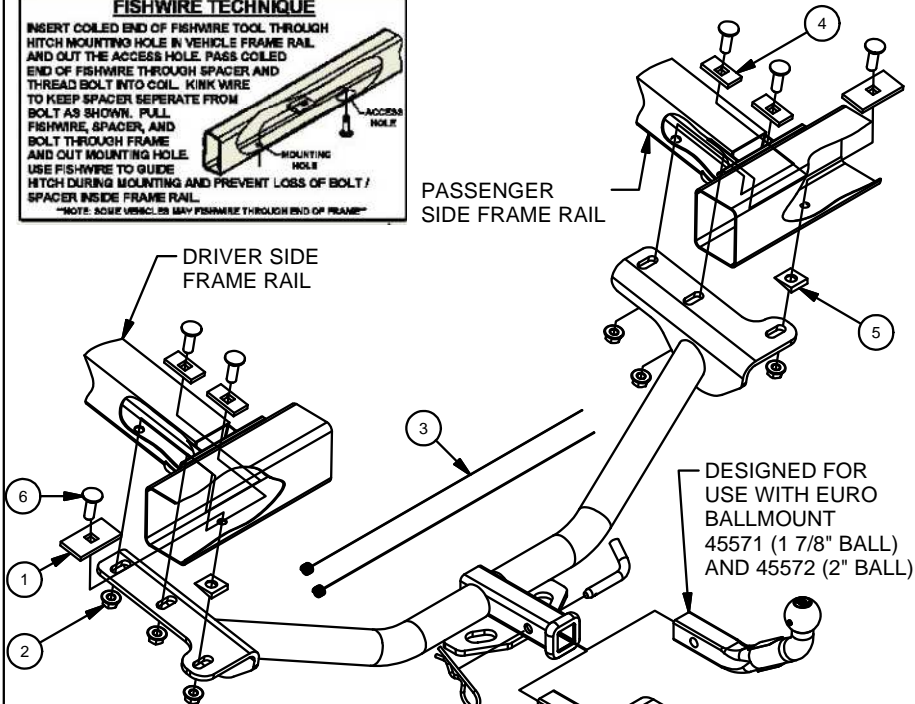

RUBBER ISOLATOR REMOVAL DIAGRAM

This technique can be used if an Exhaust Hanger Removal Pliers is not available.

Using a 5/8" open end wrench, slide the wrench up to the rubber isolator, cradling the hanger rod as shown. Next place the flat edge of a pry bar between the wrench and the hanger stop or hanger rod. Then simply rotate the pry bar toward the wrench to remove the rubber isolator.

Note: Using a spray lubricant or soapy water on the hanger rod and the rubber isolator helps removal.

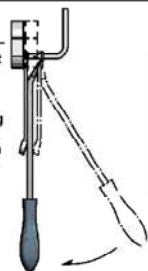

DESIGNED FOR USE WITH 45521 BALLMOUNT

FRONT
↓
REAR

1.) Lower exhaust by removing rubber isolators (3 each side) as shown.

Note: Support exhaust from underneath after lowering.

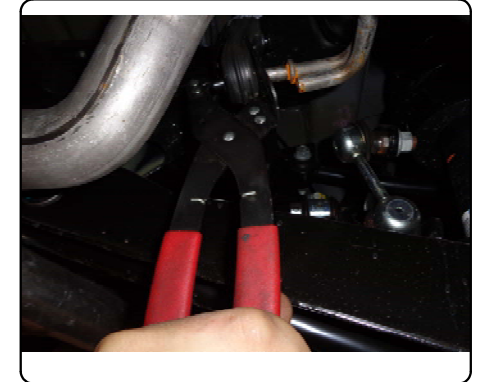

2.) Fishwire the carriage bolts and small square hole spacers through the space between the bumper beam and the end of the frame rail for both sides.



INSTALLATION WALKTHROUGH:

3.) Fishwire the remaining carriage bolts and large spacers through the bumper beam and into position.



4.) Raise hitch into position with the "wedge" shaped spacers between as shown and secure with hex flange nuts.

Note: If equipped, temporarily disconnect driver side electrical connector for clearance while securing the hitch.

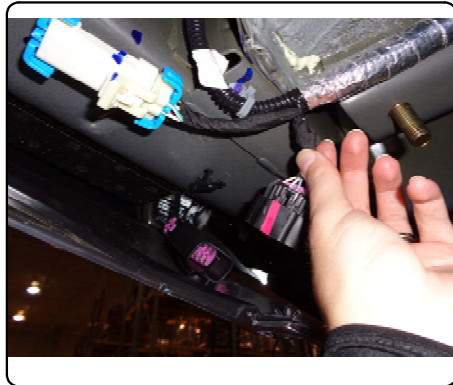

5.) Torque all 1/2" fasteners to 110 lb-ft.

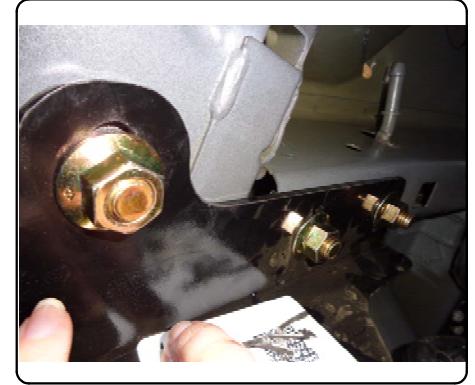

6.) Raise exhaust back into position and reinstall the (4) rubber isolators removed in Step 1.

Note: Apply lubricant or soapy water to ease installation.



12134

DODGE JOURNEY (INCLUDING CROSSROAD)

11/17/2014

GROSS LOAD CAPACITY WHEN USED AS A WEIGHT CARRYING HITCH: 3,500 LBS. TRAILER WEIGHT & 350 LBS. TONGUE WEIGHT.
 GROSS LOAD CAPACITY WHEN USED AS A WEIGHT DISTRIBUTION HITCH: N/A LBS. TRAILER WEIGHT & N/A LBS. TONGUE WEIGHT

*** DO NOT EXCEED VEHICLE MANUFACTURER'S RECOMMENDED TOWING CAPACITY.***

HAVING INSTALLATION QUESTIONS? CALL TECHNICAL SUPPORT AT 1-800-798-0813

Parts List			
ITEM	QTY	PART NUMBER	DESCRIPTION
1	2	CM-SP4	.250 x 1.50 x 3.00" SQUARE HOLE SPACER
2	6	HFN 1213	HEX FLANGE NUT
3	6	1/2-13 x 1 1/2	CARRIAGE BOLT
4	2	1_2 FISHWIRE	1/2" FISHWIRE
5	4	CM-SP12	.250 x 1.00 x 2.00" SQUARE HOLE SPACER
6	2	CM-SP38	1/2" WEDGE SPACER

FISHWIRE TECHNIQUE

INSERT COILED END OF FISHWIRE TOOL THROUGH HITCH MOUNTING HOLE IN VEHICLE FRAME RAIL AND OUT THE ACCESS HOLE. PASS COILED END OF FISHWIRE THROUGH SPACER AND THREAD BOLT INTO COIL. KINK WIRE TO KEEP SPACER SEPERATE FROM BOLT AS SHOWN. PULL FISHWIRE, SPACER, AND BOLT THROUGH FRAME AND OUT MOUNTING HOLE. USE FISHWIRE TO GUIDE HITCH DURING MOUNTING AND PREVENT LOSS OF BOLT / SPACER INSIDE FRAME RAIL.

***NOTE: SOME VEHICLES MAY FISHWIRE THROUGH END OF FRAME**

RUBBER ISOLATOR REMOVAL DIAGRAM

This technique can be used if an Exhaust Hanger Removal Pliers is not available.

Using a 5/8" open end wrench, slide the wrench up to the rubber isolator, cradling the hanger rod as shown. Next place the flat edge of a pry bar between the wrench and the hanger stop or hanger rod. Then simply rotate the pry bar toward the wrench to remove the rubber isolator.

Note: Using a spray lubricant or soapy water on the hanger rod and the rubber isolator helps removal.

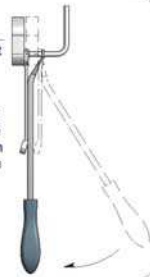

PASSENGER SIDE FRAME RAIL

DRIVER SIDE FRAME RAIL

FISHWIRE CARRIAGE BOLTS THROUGH SPACE BETWEEN THE BUMPER BEAM AND THE FRAME RAIL (FOR BOTH SIDES)

DESIGNED FOR USE WITH EURO BALLMOUNT 45571 (1 7/8" BALL) AND 45572 (2" BALL)

DESIGNED FOR USE WITH 45521 BALLMOUNT

FRONT
↓
REAR

RATCHET
3/4" SOCKET
TORQUE WRENCH
6" SOCKET EXTENSION
SMALL PRY BAR

HITCH WEIGHT: 22 LBS.

INSTALL TIME

PROFESSIONAL: 30 MINUTES

NOVICE (DIY): 60 MINUTES

INSTALL NOTES:

- LOWER SPARE TIRE
- LOWER EXHAUST
- FISHWIRE HARDWARE
- NO DRILLING REQUIRED

INSTALLATION STEPS

- 1) Lower exhaust by removing rubber isolators (3 each side) as shown in the above diagram.
NOTE: Support exhaust from underneath after lowering.
- 2) Fishwire the carriage bolts and small square hole spacers through the space between the bumper beam and the end of the frame rail for both sides.
- 3) Fishwire the remaining carriage bolts and large spacers through the bumper beam and into position.
- 4) Raise hitch into position with the "wedge" shaped spacers between as shown and secure with hex flange nuts.
NOTE: If equipped, temporarily disconnect driver side electrical connector for clearance while securing the hitch.
- 5) Torque all 1/2" fasteners to 110 lb-ft.
- 6) Raise exhaust back into position and reinstall the (4) rubber isolators removed in Step 1.
NOTE: Apply lubricant or soapy water to ease installation.



Scan for more information

PERIODICALLY CHECK THIS RECEIVER HITCH TO ENSURE THAT ALL FASTENERS ARE TIGHT AND THAT ALL STRUCTURAL COMPONENTS ARE SOUND.

CURT Manufacturing LLC., warrants this product to be free of defects in material and/or workmanship at the time of retail purchase by the original purchaser. If the product is found to be defective, CURT Manufacturing LLC., may repair or replace the product, at their option, when the product is returned, prepaid, with proof of purchase. Alteration to, misuse of, or improper installation of this product voids the warranty. CURT Manufacturing LLC.'s liability is limited to repair or replacement of products found to be defective, and specifically excludes liability for incidental or consequential loss or damage.