

YEARS: 2005-PRESENT

MAKE: VW

MODEL: JETTA, GOLF (CANADA)

STYLE: SEDAN/WAGON

**WARNING: NEVER EXCEED YOUR VEHICLE MANUFACTURER'S RECOMMENDED TOWING CAPACITY**  
 For more information log onto [www.curtmfg.com](http://www.curtmfg.com) & for helpful towing tips log onto [www.hitchinfo.com](http://www.hitchinfo.com)

**WEIGHT CARRYING:**  
 TRAILER WEIGHT: 2,000 LBS.  
 TONGUE WEIGHT: 200 LBS.

**WARNING:**  
 WE RECOMMEND THE USE OF 18050 STABILIZING STRAPS FOR ALL NON-TRAILER (WHEEL-LESS) LOADS. PLEASE SEE THE CURT CATALOG OR VISIT US ONLINE AT [WWW.CURTMFG.COM](http://WWW.CURTMFG.COM) FOR FURTHER INFORMATION.

**PRO INSTALL TIME: 45 MIN.**  
**NOVICE INSTALL TIME: 90 MIN.**

IF YOU ARE HESITANT TO UNDERTAKE THIS TASK ON YOUR OWN, CONTACT AN AUTHORIZED CURT INSTALLER FOR ADDITIONAL ASSISTANCE.

**INSTALLATION REQUIRES:**

RATCHET	10mm 13mm 3/4" 11/16" SOCKET	TAPE MEASURE
10" SOCKET EXTENSION	TORQUE WRENCH	ROTARY TOOL
#25 TORXBIT SOCKET	#27 TORXBIT SOCKET	SAFETY GLASSES

**INSTALLATION TIPS:**

- BEFORE YOU BEGIN INSTALLATION, READ ALL INSTRUCTIONS THOROUGHLY.
- TO EASE INSTALLATION, 2 PEOPLE MAY BE REQUIRED.
- USING PROPER TOOLS WILL GREATLY IMPROVE THE QUALITY OF THE INSTALL AND REDUCE THE TIME REQUIRED.
- NEED HELP OR HAVE SOME QUESTIONS? CALL TECHNICAL SUPPORT AT 800.798.0813

**LEVEL OF DIFFICULTY: MODERATE**

EASY	MODERATE	CHALLENGING
NO DRILLING REQUIRED		
TEMPORARILY LOWER EXHAUST		
FISHWIRE HARDWARE		
TRIM	TRIM UNDERBODY PANEL	

**VEHICLE PHOTO:**



REPRESENTATIVE PHOTO

**HITCH ILLUSTRATION:**

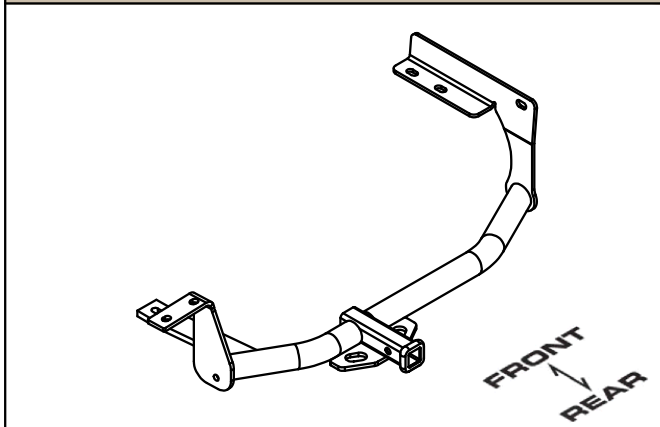

MAKE SURE YOUR HITCH MATCHES



**PERIODICALLY CHECK THIS RECEIVER HITCH TO ENSURE ALL FASTENERS ARE TIGHT AND ALL STRUCTURAL COMPONENTS ARE SOUND**  
 CURT Manufacturing LLC. warrants this product to be free of defects in material and/or workmanship at the time of retail purchase by the original purchaser. If the product is found to be defective, CURT Manufacturing LLC. may repair or replace the product at their option, when the product is returned, prepaid, with proof of purchase. Alteration to, misuse of, or improper installation of this product voids the warranty. CURT Manufacturing LLC.'s liability is limited to repair or replacement of products found to be defective, and specifically excludes liability for incidental or consequential loss or damage.  
 For more information log onto [www.curtmfg.com](http://www.curtmfg.com)  
 This product complies with safety specifications and requirements for connecting devices and towing systems of the state of New York, V.E.S.C.Regulation V-5 and SAE J684.

# INSTALLATION WALKTHROUGH:

Parts List			
ITEM	QTY	PART NUMBER	DESCRIPTION
1	3	7/16 - 14 x 1 3/4	CARRIAGE BOLT
2	3	CM-SP2	.250 x .88 x 2.25" SQUARE HOLE SPACER
3	3	7/16-14	HEX FLANGE NUT
4	1	1/2-13 x 1 3/4	CARRIAGE BOLT
5	1	HFN 1213	HEX FLANGE NUT
6	2	M8 - 1.25 x 35 HFB	M8-1.25 x 35 HEX FLANGE BOLT
7	3	7_16 FISHWIRE	7/16" FISHWIRE
8	1	11474-SP	.250" SPACER

### FISHWIRE TECHNIQUE

INSERT COILED END OF FISHWIRE TOOL THROUGH HITCH MOUNTING HOLE IN VEHICLE FRAME RAIL AND OUT THE ACCESS HOLE. PASS COILED END OF FISHWIRE THROUGH SPACER AND THREAD BOLT INTO COIL. KINK WIRE TO KEEP SPACER SEPARATE FROM BOLT AS SHOWN. PULL FISHWIRE, SPACER, AND BOLT THROUGH FRAME AND OUT MOUNTING HOLE. USE FISHWIRE TO GUIDE HITCH DURING MOUNTING AND PREVENT LOSS OF BOLT / SPACER INSIDE FRAME RAIL.

\*\*NOTE: SOME VEHICLES MAY FISHWIRE THROUGH END OF FRAME\*\*

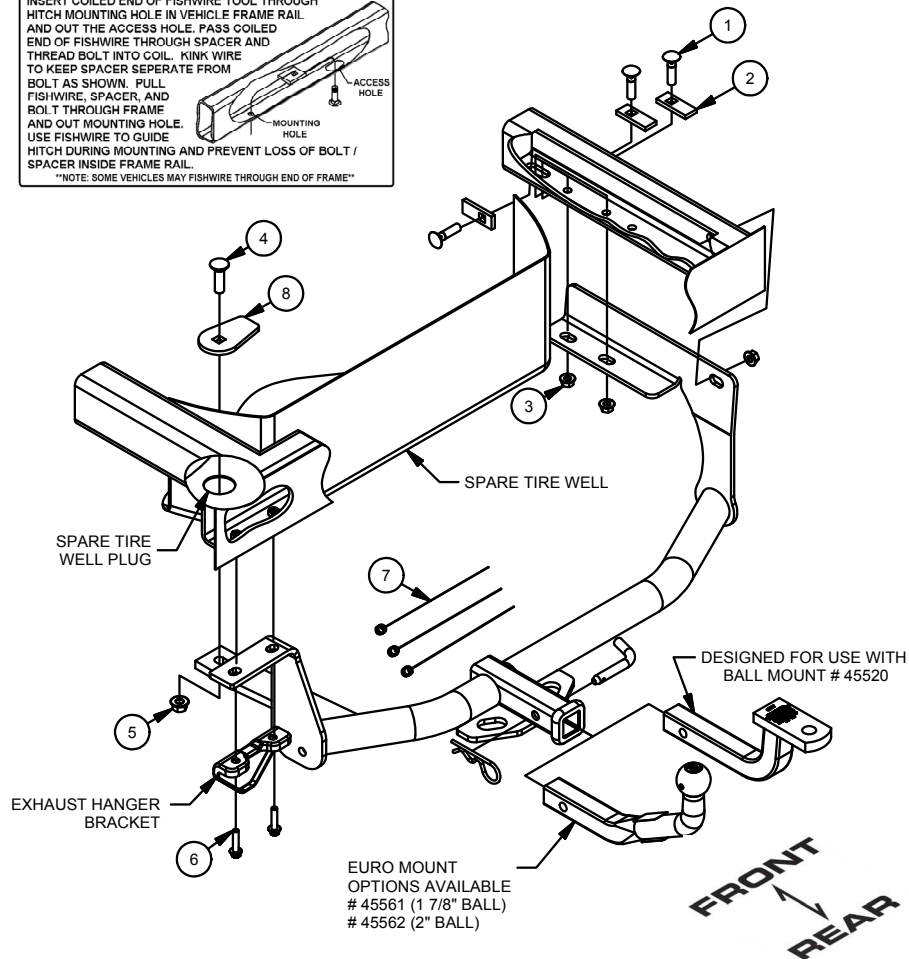
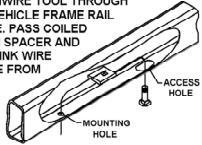

1. Lower the passenger side underbody panel by removing (3) torx head screws and (2) hex nuts. (Save fasteners for use in Step 12.)
2. If fuel vapor canistor is present on passenger side, lower by removing (3) hex head flange bolts. (Save fasteners for use in Step 11.)



3. Lower the exhaust by removing the (2) hex flange bolts from exhaust hanger bracket. Return to vehicle owner. (Leave the muffler attached to the exhaust hanger bracket.)
4. Fishwire a 7/16" carriage bolt and CM-SP2 spacer through the access hole and out each of the two forward holes in the bottom of the passenger side frame rail as shown. (See Fishwire Technique.)



## INSTALLATION WALKTHROUGH:

5. Remove the contents of the trunk, including the spare tire. Remove the forward plug on the driver side of the spare tire well. Return plug to vehicle owner.
6. Raise hitch into position over the exhaust, threading the passenger side fishwires through the slots in the passenger side mounting plate. Secure the passenger side with the (2) 7/16" hex flange nuts as shown. Take care not to push the carriage bolts into the frame rail.



7. Position the driver side mount plate between the exhaust hanger bracket and the driver side frame rail and secure using the (2) M8 hex flange bolts as shown.
8. Fishwire the remaining 7/16" carriage bolt and CM-SP2 spacer through the access hole and out the slotted hole on the outer side of the passenger side frame rail as shown and secure with a hex flange nut. Take care not to drop the carriage bolt in the frame rail. (See Fishwire Technique on page 2.)



9. Use silicone caulk (or equivalent) to seal the tire well plug hole from exhaust fumes and water by putting a bead around the hole inside the trunk. Place a 11474-SP spacer onto the hole and put a bead of caulk around the square hole. Install a 1/2" carriage bolt and secure with a hex flange nut from under the vehicle as shown.
10. Torque all M8 hardware to 23 ft-lbs., all 7/16" hardware to 70 ft-lbs. and all 1/2" hardware to 110 ft-lbs.



11. Reinstall the fuel vapor canistor using the hardware removed in Step 2.
12. Trim rear underbody panel to clear the passenger side plate as shown in the Underbody Panel Trim Diagram(s). (NOTE: WAGON OR SEDAN) Reinstall the underbody panel using the torx head screws and hex nuts removed in Step 1.
13. Return spare tire and other items removed to the trunk.

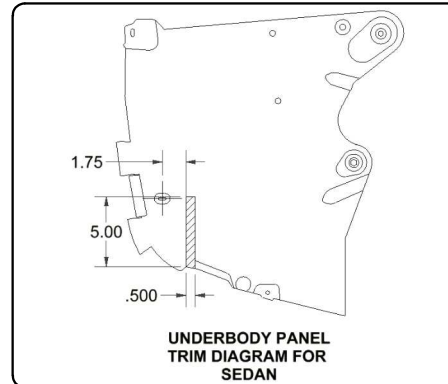

UNDERBODY PANEL  
TRIM DIAGRAM FOR  
SEDAN

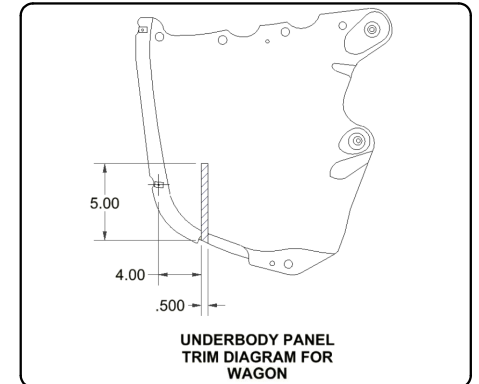

UNDERBODY PANEL  
TRIM DIAGRAM FOR  
WAGON



## TOWING SAFETY INFORMATION

### Gross Trailer Weight / GTW

The Gross Trailer Weight is the weight of the trailer & cargo. Measure this by putting the fully loaded trailer on a vehicle scale.

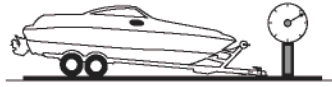

### Tongue Weight / TW

The downward force that is exerted on the hitch ball by the coupler. The tongue weight will vary depending on where the load is positioned in relationship to the trailer axle(s). To measure the tongue weight, use either a commercial scale or a bathroom scale with the coupler at towing height. When using a bathroom scale with heavier tongue weights, use the method shown and multiply the scale reading by 3.

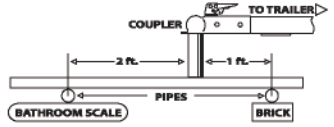

### Weight Carrying / WC

The total weight of both the trailer and the cargo inside. Never exceed the weight capacity of your trailer hitch.

### Weight Distribution / WD

Used to balance the weight of the cargo between the front and rear wheels throughout the trailer, allowing for better steering, braking, and level riding.



### Sway Control

A device used to reduce the lateral movements of the trailer that are caused by the wind. This works in conjunction with a weight distribution hitch. Do not use this on a class 1 or 2 hitch, or with surge brakes.

### How Much Can You Safely Tow?

TONGUE WEIGHT lbs	1000	2000	3000	4000	5000	6000	7000	8000	10,000	12,000
Tongue weight should be about 10 to 15 percent of the gross trailer weight.										
CLASS 1										
CLASS 2										
CLASS 3										
CLASS 4										
CLASS 5										
<b>Camper</b>	11'	12'	13'	14'	15'	16'				
lbs	1100	1200	1300	1400	1500	1600				
<b>Vacation</b>	14'	16'	18'	20'	22'	24'	26'	28'	30'	32'
lbs	2100	2400	2700	3000	3300	3600	3900	4200	4500	4800
<b>Vacation</b>	14'	16'	18'	20'	22'	24'	26'	28'	30'	32'
lbs	2800	3200	3600	4000	4400	4800	5200	5600	6000	6400
<b>5th Wheel</b>										

Refer to owner's manual for towing capabilities and limitations.

### Ball Mount

The ball mount is placed inside the opening of the receiver hitch which is mounted to the vehicle. Make sure a hitch pin and clip is properly securing the ball mount to the receiver hitch before you begin towing.

- A: Rise. B: Drop. C: Hole Size. D: Length.

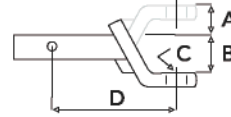

### Trailer Ball

The connection from the hitch to the trailer. There are many factors that determine the correct hitch ball:

- Number one is the hitch ball's gross trailer weight rating.
- The mounting platform must be at least 3/8" thick.
- The hole diameter must not be more than 1/16" larger than the threaded shank.
- Every time you tow, check the nut and lock washer to make sure they are fastened securely.
- A: Ball Dia. B: Shank Dia. C: Shank Length. D: Shank Rise.

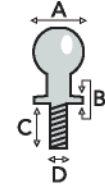

### Coupler

The component that is placed over the trailer ball to connect the vehicle to the trailer. Be sure that the coupler size matches the size of the hitch ball and that the coupler handle is securely fastened. To determine what size hitch ball you need for your application you will need to know the size of coupler that is on the trailer. Be sure your coupler is properly adjusted to the ball you are using.

NOTE: For added security the use of safety devices such as Coupler Safety Pins and Locks is strongly recommended.

### Safety Chains

Safety chains are a requirement and should be crossed under the tongue of the trailer so that the tongue will not drop to the road if it becomes separated from the hitch. Always leave enough slack so you can turn. Never allow the safety chains to drag on the ground and never attach the chains to the bumper.

Trailer Classification: Safety Chain Breaking Force - Minimum

Class 1: 2,000 lbs. (8.9 kN)

Class 2: 3,500 lbs. (15.6 kN)

Class 3: 5,000 lbs. (22.2 kN)

The strength rating of each length of safety chain or its equivalent and its attachments shall be equal to or exceed in minimum breaking force the GVWR (Gross Vehicle Weight Rating) of the trailer.

### Electrical

Trailer lights, Electric Brakes, Break-away systems - Every time you tow, be sure to check that all components are working properly.

Wiring identification by color:

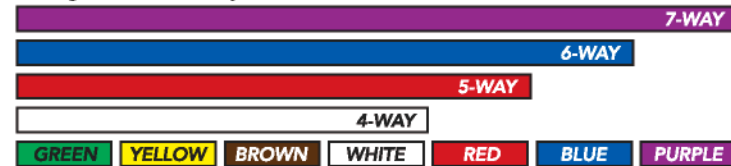

GROSS LOAD CAPACITY WHEN USED AS A WEIGHT CARRYING HITCH: 2,000 LBS. TRAILER WEIGHT & 200 LBS. TONGUE WEIGHT.

WARNING: ALL NON-TRAILER LOADS APPLIED TO THIS PRODUCT MUST BE SUPPORTED BY 18050 STABILIZING STRAPS.



**WARNING: \*\* FAILURE TO PROPERLY SUPPORT NON-TRAILER LOADS WILL VOID PRODUCT WARRANTY \*\***

**WARNING: \*\*\* DO NOT EXCEED VEHICLE MANUFACTURER'S RECOMMENDED TOWING CAPACITY \*\*\***



FOR MORE INFORMATION LOG ONTO WWW.CURTMFG.COM  
HAVING INSTALLATION QUESTIONS? CALL TECHNICAL SUPPORT AT 1-800-798-0813

Parts List			
ITEM	QTY	PART NUMBER	DESCRIPTION
1	3	7/16 - 14 x 1 3/4	CARRIAGE BOLT
2	3	CM-SP2	.250 x .88 x 2.25" SQUARE HOLE SPACER
3	3	7/16-14	HEX FLANGE NUT
4	1	1/2-13 x 1 3/4	CARRIAGE BOLT
5	1	HFN 1213	HEX FLANGE NUT
6	2	M8 - 1.25 x 35 HFB	M8-1.25 x 35 HEX FLANGE BOLT
7	3	7_16 FISHWIRE	7/16" FISHWIRE
8	1	11474-SP	.250" SPACER

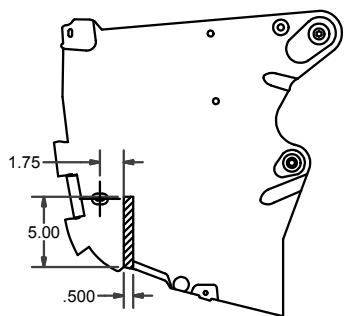

UNDERBODY PANEL TRIM DIAGRAM FOR SEDAN

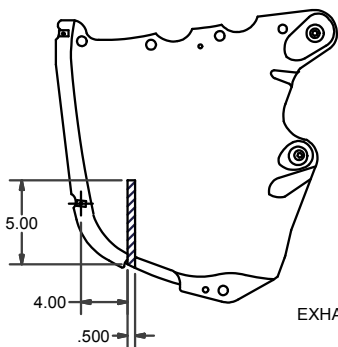

UNDERBODY PANEL TRIM DIAGRAM FOR WAGON

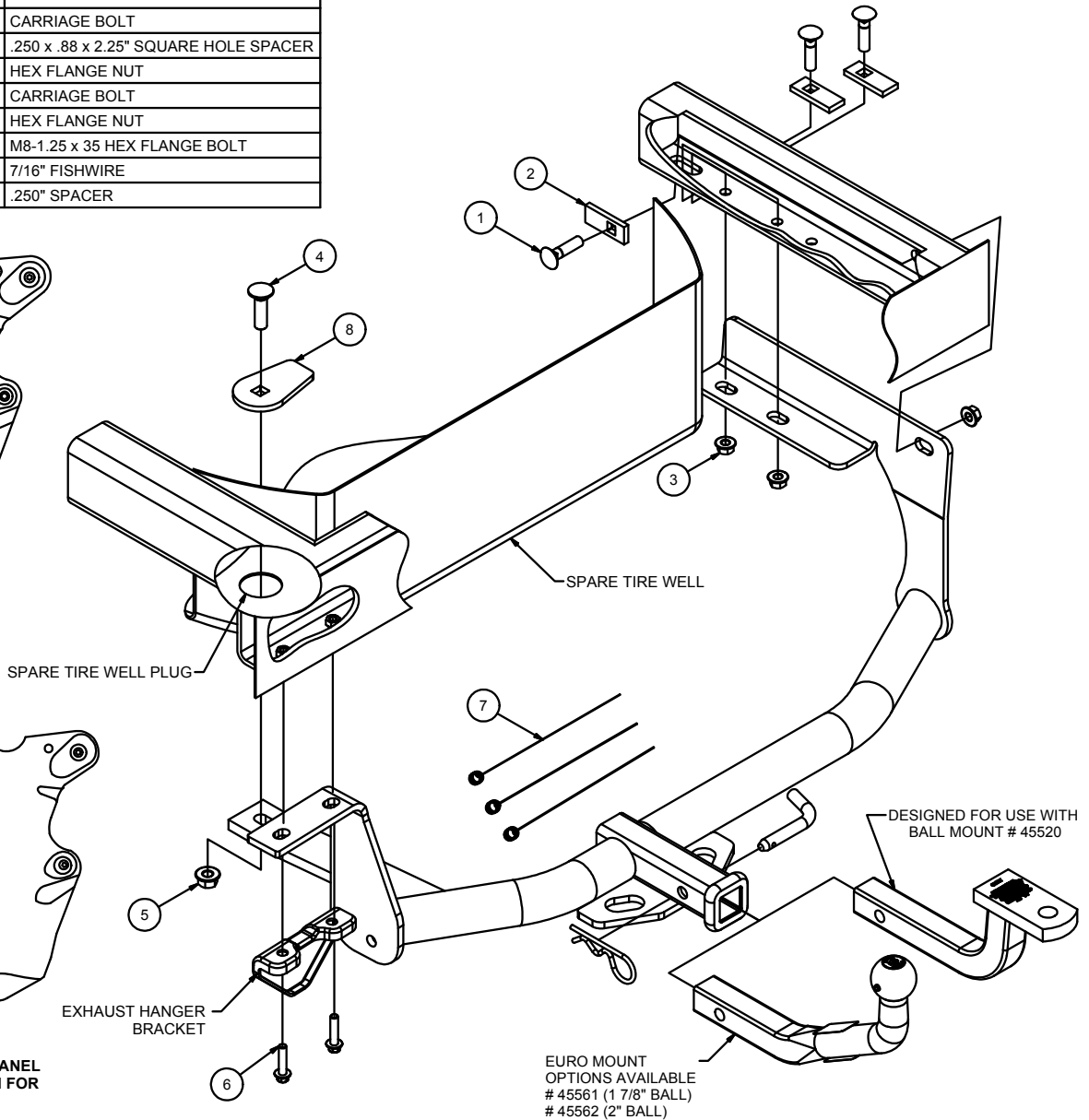

TOOLS REQUIRED
#25 AND #27 TORX DRIVERS
10mm AND 13mm SOCKETS
3/4" AND 11/16" SOCKETS
10" EXTENSION
RATCHET
TORQUE WRENCH
ROTARY CUTTING TOOL
TAPE MEASURE
SAFETY GLASSES

HITCH WEIGHT: 29 LBS.

INSTALL TIME

PROFESSIONAL: 45 MINUTES

NOVICE (DIY): 90 MINUTES

INSTALL NOTES:

- NO DRILLING REQUIRED
- LOWER EXHAUST
- FISHWIRE HARDWARE
- TRIM UNDERBODY PANEL

**PERIODICALLY CHECK THIS RECEIVER HITCH TO ENSURE THAT ALL FASTENERS ARE TIGHT AND THAT ALL STRUCTURAL COMPONENTS ARE SOUND.**



Scan for more information

CURT Manufacturing LLC., warrants this product to be free of defects in material and/or workmanship at the time of retail purchase by the original purchaser. If the product is found to be defective, CURT Manufacturing LLC., may repair or replace the product, at their option, when the product is returned, prepaid, with proof of purchase. Alteration to, misuse of, or improper installation of this product voids the warranty. CURT Manufacturing LLC.'s liability is limited to repair or replacement of products found to be defective, and specifically excludes liability for incidental or consequential loss or damage.

This product complies with safety specifications and requirements for connecting devices and towing systems of the state of New York, V.E.S.C.Regulation V-5 and SAE J684.

HAVING INSTALLATION QUESTIONS? CALL TECHNICAL SUPPORT AT 1-800-798-0813

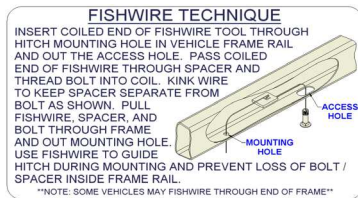

FUEL VAPOR CANISTER

## INSTALLATION STEPS

1. Lower the passenger side underbody panel by removing (3) torx head screws and (2) hex nuts. (Save fasteners for use in Step 12.)
2. If fuel vapor canister is present on passenger side, lower by removing (3) hex head flange bolts. (Save fasteners for use in Step 11.)
3. Lower the exhaust by removing the (2) hex flange bolts from exhaust hanger bracket. Return to vehicle owner. (Leave the muffler attached to the exhaust hanger bracket.)
4. Fishwire a 7/16" carriage bolt and CM-SP2 spacer through the access hole and out each of the two forward holes in the bottom of the passenger side frame rail as shown. (See Fishwire Technique.)
5. Remove the contents of the trunk, including the spare tire. Remove the forward plug on the driver side of the spare tire well. Return plug to vehicle owner.
6. Raise hitch into position over the exhaust, threading the passenger side fishwires through the slots in the passenger side mounting plate. Secure the passenger side with the (2) 7/16" hex flange nuts as shown. Take care not to push the carriage bolts into the frame rail.
7. Position the driver side mount plate between the exhaust hanger bracket and the driver side frame rail and secure using the (2) M8 hex flange bolts as shown.
8. Fishwire the remaining 7/16" carriage bolt and CM-SP2 spacer through the access hole and out the slotted hole on the outer side of the passenger side frame rail as shown and secure with a hex flange nut. Take care not to drop the carriage bolt in the frame rail. (See Fishwire Technique above.)
9. Use silicone caulk (or equivalent) to seal the tire well plug hole from exhaust fumes and water by putting a bead around the hole inside the trunk. Place a 11474-SP spacer onto the hole and put a bead of caulk around the square hole. Install a 1/2" carriage bolt and secure with a hex flange nut from under the vehicle as shown.
10. Torque all M8 hardware to 23 ft-lbs., all 7/16" hardware to 70 ft-lbs. and all 1/2" hardware to 110 ft-lbs.
11. Reinstall the fuel vapor canister using the hardware removed in Step 2.
12. Trim rear underbody panel to clear the passenger side plate as shown in the Underbody Panel Trim Diagram(s). (NOTE: WAGON OR SEDAN) Reinstall the underbody panel using the torx head screws and hex nuts removed in Step 1.
13. Return spare tire and other items removed to the trunk.

**PERIODICALLY CHECK THIS RECEIVER HITCH TO ENSURE THAT ALL FASTENERS ARE TIGHT AND THAT ALL STRUCTURAL COMPONENTS ARE SOUND.**

CURT Manufacturing LLC., warrants this product to be free of defects in material and/or workmanship at the time of retail purchase by the original purchaser. If the product is found to be defective, CURT Manufacturing LLC., may repair or replace the product, at their option, when the product is returned, prepaid, with proof of purchase. Alteration to, misuse of, or improper installation of this product voids the warranty. CURT Manufacturing LLC.'s liability is limited to repair or replacement of products found to be defective, and specifically excludes liability for incidental or consequential loss or damage.

This product complies with safety specifications and requirements for connecting devices and towing systems of the state of New York, V.E.S.C.Regulation V-5 and SAE J684.