

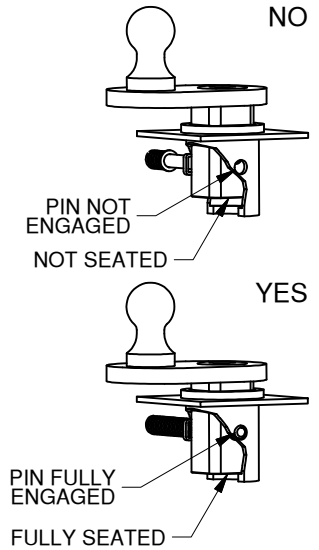

Turnoverball® Gooseneck Extender 20,000 lb. GTW 5,000 lb. VTW

INSTALLATION AND MAINTENANCE

- The Turnoverball Gooseneck Extenders are not designed to be used with plastic bed liners or other addition to the bed floor which prohibits the Gooseneck Extender from being fully seated inside the Turnoverball receiver socket, or being engaged by the Turnoverball latch pin.
- Retract the latch pin handle and remove the 2-5/16" ball or other turnoverball accessory from the ball socket. Place the square post of the Extender into Turnoverball socket, so that the ball is closer to the rear of the pickup than the square post. Engage the Turnoverball latch pin. Make sure that the latch pin fully engages the square post of the Extender.
- For hitch accessories that remain in the Turnoverball receiver for an extended period of time, B&W recommends lightly lubricating the four corners of the square post with grease.



Turnoverball® Gooseneck Extender 20,000 lb. GTW 5,000 lb. VTW

INSTALLATION AND MAINTENANCE

- The Turnoverball Gooseneck Extenders are not designed to be used with plastic bed liners or other addition to the bed floor which prohibits the Gooseneck Extender from being fully seated inside the Turnoverball receiver socket, or being engaged by the Turnoverball latch pin.
- Retract the latch pin handle and remove the 2-5/16" ball or other turnoverball accessory from the ball socket. Place the square post of the Extender into Turnoverball socket, so that the ball is closer to the rear of the pickup than the square post. Engage the Turnoverball latch pin. Make sure that the latch pin fully engages the square post of the Extender.
- For hitch accessories that remain in the Turnoverball receiver for an extended period of time, B&W recommends lightly lubricating the four corners of the square post with grease.

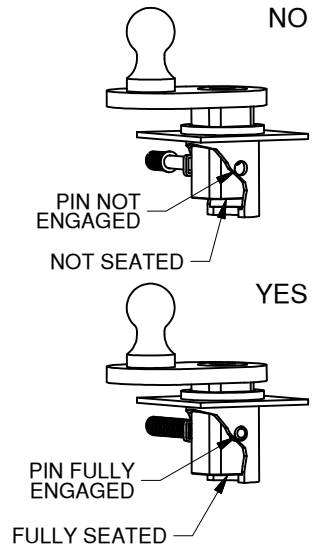

Turnoverball® Gooseneck Extender 20,000 lb. GTW 5,000 lb. VTW

INSTALLATION AND MAINTENANCE

- The Turnoverball Gooseneck Extenders are not designed to be used with plastic bed liners or other addition to the bed floor which prohibits the Gooseneck Extender from being fully seated inside the Turnoverball receiver socket, or being engaged by the Turnoverball latch pin.
- Retract the latch pin handle and remove the 2-5/16" ball or other turnoverball accessory from the ball socket. Place the square post of the Extender into Turnoverball socket, so that the ball is closer to the rear of the pickup than the square post. Engage the Turnoverball latch pin. Make sure that the latch pin fully engages the square post of the Extender.
- For hitch accessories that remain in the Turnoverball receiver for an extended period of time, B&W recommends lightly lubricating the four corners of the square post with grease.

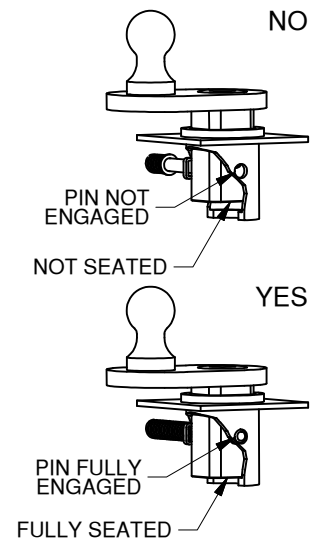

⚠️ WARNING

Failure to comply with the safety information in these instructions could result in serious injury or death.

- ⚠️ The Extender comes equipped with a 2 5/16" ball. Trailers towed with the ball provided must have a 2 5/16" coupler. Towing with a larger coupler could cause loss of attachment between the trailer and the tow vehicle.
- ⚠️ Do not exceed tow or tongue rating of coupler, tow or tongue rating of hitch, or tow or weight ratings of truck or trailer. See vehicle and trailer manufacturer information for ratings. Exceeding these ratings may cause damage to towing components or loss of attachment between the trailer and truck.
- ⚠️ A visual inspection of the hitch should be performed before each time you tow. Regularly check that all pinned connections are secure, and that all bolted connections are at the correct torque specification. Check for cracks or damage to the hitch. Do not tow with the hitch if cracks or damage outside of normal wear is found. Towing with a hitch that has cracks or damage could result in damage to the tow vehicle, trailer, towing components and loss of attachment between the tow vehicle and trailer.

- ⚠️ Always check turning clearance before towing. Compare the measurement taken from the center of the Coupler to the cab, to the measurement taken from the center of the 2 5/16" ball to the farthest forward corner point of the trailer. These measurements will allow you to see how much clearance you will have between the cab and the trailer while towing and turning.

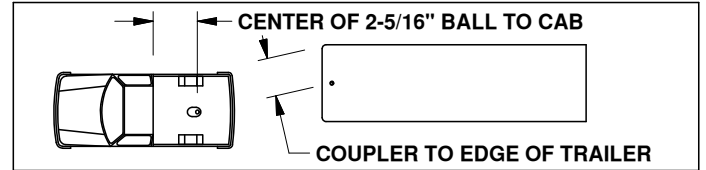

- ⚠️ Do not tow with any damaged or worn parts. Towing with compromised equipment could cause loss of attachment between the trailer and the tow vehicle. *Surface finish wear does not constitute damage.*

Copyright 2020
B&W Custom Truck Beds, Inc.
ALL RIGHTS RESERVED
HITCH EXTENDER 01 29 2020

⚠️ WARNING

Failure to comply with the safety information in these instructions could result in serious injury or death.

- ⚠️ The Extender comes equipped with a 2 5/16" ball. Trailers towed with the ball provided must have a 2 5/16" coupler. Towing with a larger coupler could cause loss of attachment between the trailer and the tow vehicle.
- ⚠️ Do not exceed tow or tongue rating of coupler, tow or tongue rating of hitch, or tow or weight ratings of truck or trailer. See vehicle and trailer manufacturer information for ratings. Exceeding these ratings may cause damage to towing components or loss of attachment between the trailer and truck.
- ⚠️ A visual inspection of the hitch should be performed before each time you tow. Regularly check that all pinned connections are secure, and that all bolted connections are at the correct torque specification. Check for cracks or damage to the hitch. Do not tow with the hitch if cracks or damage outside of normal wear is found. Towing with a hitch that has cracks or damage could result in damage to the tow vehicle, trailer, towing components and loss of attachment between the tow vehicle and trailer.

- ⚠️ Always check turning clearance before towing. Compare the measurement taken from the center of the Coupler to the cab, to the measurement taken from the center of the 2 5/16" ball to the farthest forward corner point of the trailer. These measurements will allow you to see how much clearance you will have between the cab and the trailer while towing and turning.

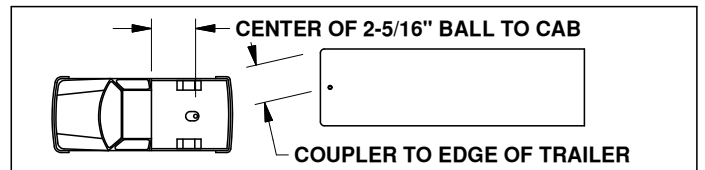

- ⚠️ Do not tow with any damaged or worn parts. Towing with compromised equipment could cause loss of attachment between the trailer and the tow vehicle. *Surface finish wear does not constitute damage.*

Copyright 2020
B&W Custom Truck Beds, Inc.
ALL RIGHTS RESERVED
HITCH EXTENDER 01 29 2020

⚠️ WARNING

Failure to comply with the safety information in these instructions could result in serious injury or death.

- ⚠️ The Extender comes equipped with a 2 5/16" ball. Trailers towed with the ball provided must have a 2 5/16" coupler. Towing with a larger coupler could cause loss of attachment between the trailer and the tow vehicle.
- ⚠️ Do not exceed tow or tongue rating of coupler, tow or tongue rating of hitch, or tow or weight ratings of truck or trailer. See vehicle and trailer manufacturer information for ratings. Exceeding these ratings may cause damage to towing components or loss of attachment between the trailer and truck.
- ⚠️ A visual inspection of the hitch should be performed before each time you tow. Regularly check that all pinned connections are secure, and that all bolted connections are at the correct torque specification. Check for cracks or damage to the hitch. Do not tow with the hitch if cracks or damage outside of normal wear is found. Towing with a hitch that has cracks or damage could result in damage to the tow vehicle, trailer, towing components and loss of attachment between the tow vehicle and trailer.

- ⚠️ Always check turning clearance before towing. Compare the measurement taken from the center of the Coupler to the cab, to the measurement taken from the center of the 2 5/16" ball to the farthest forward corner point of the trailer. These measurements will allow you to see how much clearance you will have between the cab and the trailer while towing and turning.

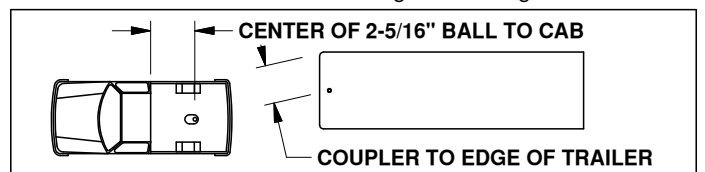

- ⚠️ Do not tow with any damaged or worn parts. Towing with compromised equipment could cause loss of attachment between the trailer and the tow vehicle. *Surface finish wear does not constitute damage.*

Copyright 2020
B&W Custom Truck Beds, Inc.
ALL RIGHTS RESERVED
HITCH EXTENDER 01 29 2020