



BX2801

2012 Fiat 500 Pop Installation Instructions

Serial Number

Please read BOTH these Installation Instructions and the General Instructions before attempting to install or operate this equipment.

- Blue Ox® towing products and accessories are intended to be installed by Blue Ox® Dealers who are familiar with our products and have the equipment necessary and knowledge to do “fit work”. When necessary Blue Ox® Dealers can be found at www.blueox.com or by contacting our Customer Care Department at (402) 385-3051.
- Many Blue Ox® baseplates are designed to use existing holes and hardware to mount the baseplate to the towed vehicle. Even though bolts are there, do not assume they are adequate for baseplate mounting. Always use hardware supplied in the hardware kit and existing hardware specified in the Baseplate Installation Instructions.

Attachment Tab Height: 12”

Attachment Tab Width: 18”

Bolt Torque Specifications
Torque in Foot-Pounds for Metric Bolts

Bolt Size	Grade 8.8	Grade 10.9
6MM	6	8
8MM	16	22
10MM	31	40
12MM	54	70
14MM	89	117

Confirm the towability and pre-towing procedures for your vehicle with the owner’s manual or contact the vehicle’s manufacturer for specific towing procedures.

Bolt Torque Specifications
Torque in Foot-Pounds for Inch Bolts

Bolt Size	Grade 5	Grade 8
1/4”	10	14
5/16”	19	29
3/8”	33	47
7/16”	54	78
1/2”	78	119
5/8”	154	230



If the front of your vehicle looks different than this, call us at (402) 385-3051.

! WARNING

Failure to read and follow these instructions could result in separation of the towed vehicle from the tow bar, causing property damage, loss of towed vehicle, personal injury or death.



BX2801

2012 Fiat 500 Pop Installation Instructions

Parts List

Ref. No.	Qty.	Part #	Description
1	4	61-4978	3/8"-16 Whiz Nut Weldment with 14" Wire
2	1	61-7074	BX2801 Baseplate
3	4	201-0443	3/8"-16 x 1" Hex Head Bolt, Grade 5, ZP
4	4	203-0010	3/8" Lock Washer, ZP
5	2	226-0046 (not shown)	36" Class III Safety Cables
6	2	229-0359 (not shown)	3/8" Quicklinks, ZP

Tools Required

- 8MM Socket
- 10MM Socket
- 14MM Socket
- 9/16" Socket
- T30 Torx
- Large Vise Grip
- Reciprocating Saw
- Phillips Screwdriver
- Loctite® RED
- Utility Knife
- Torque Wrench
- Tape Measure
- Drill
- 13/32" Drill Bit
- Hammer

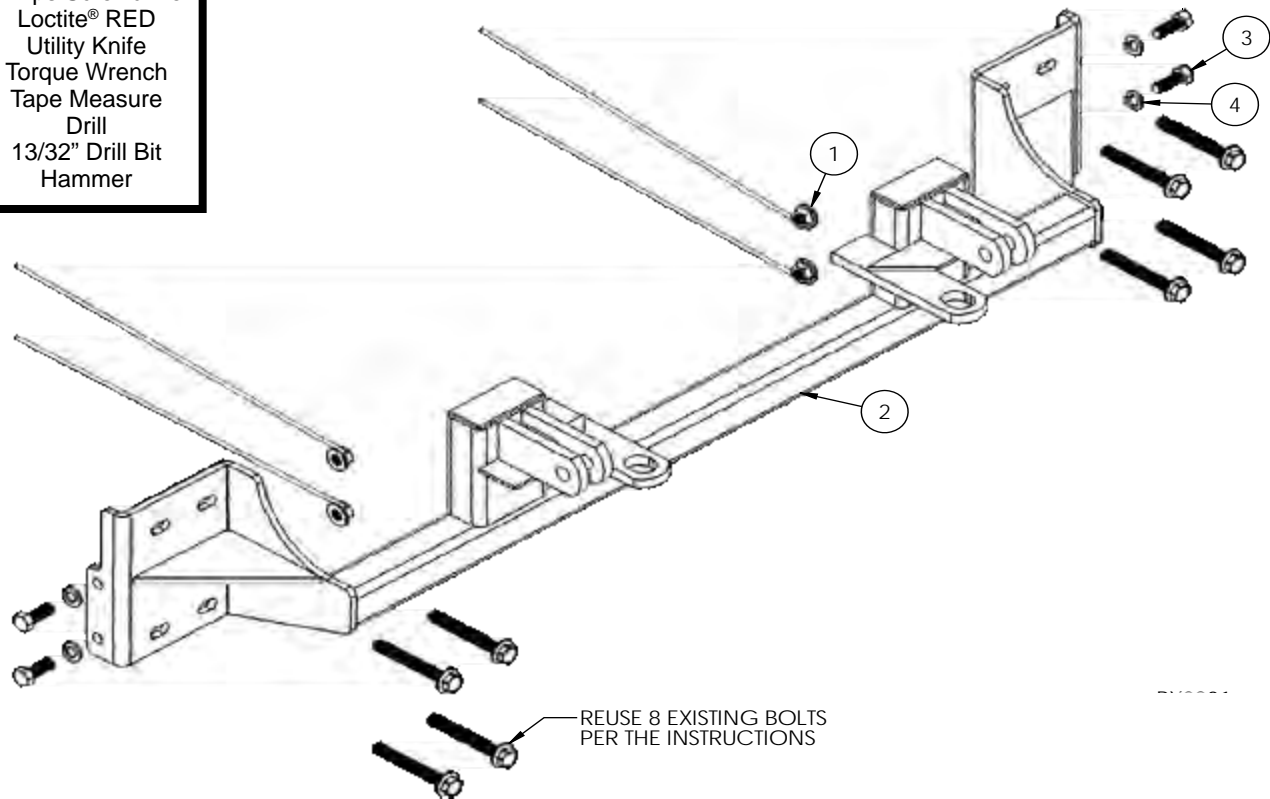

Important:

Use only genuine factory replacement parts on your baseplate. Do **NOT** substitute homemade or non-typical parts. If a bolt is lost or in need of replacement, for your safety and the preservation of your baseplate, be sure to use a replacement bolt of the same grade (In most cases it will be Grade 5, please reference the parts list above). Replacement parts may be ordered through your nearest Blue Ox® Dealer or Distributor. Failing to follow and/or altering these installation instructions in either installation or required equipment will void the manufacturer's warranty.



BX2801

2012 Fiat 500 Pop Installation Instructions

Instruction Notes: The fascia and air dam are removed and reinstalled for the baseplate installation. Some drilling is required.

Place all components that are removed on a flat, sturdy surface. These items will be reinstalled after the baseplate is installed unless otherwise noted.

The dimensional variations between otherwise identical vehicles can be considerable. While the baseplate was designed for easy installation, it may be necessary to tailor the baseplate slightly to compensate for vehicle manufacturer's tolerances.

The BX8869 Tail Light Wiring Kit is recommended for this vehicle.

NOTICE

- Handling of some cosmetic parts when installing this product may require the use of protective covers, rags, specialty tools, etc. to prevent damage.
- When using power drills be aware of the dangers of torque and drill bit length.
- Be sure that **ALL** electrical connections are plugged in properly and functioning before reinstalling the fascia.
- Do not use the towed vehicle for storing luggage, equipment, etc. This may cause you to exceed the towing capacity of the tow bar, baseplate and its accessories.
- Be sure to use Loctite® Red on all bolts before tightening. Tighten all bolts according to the torque chart provided.

BX2801

2012 Fiat 500 Pop

Installation Instructions

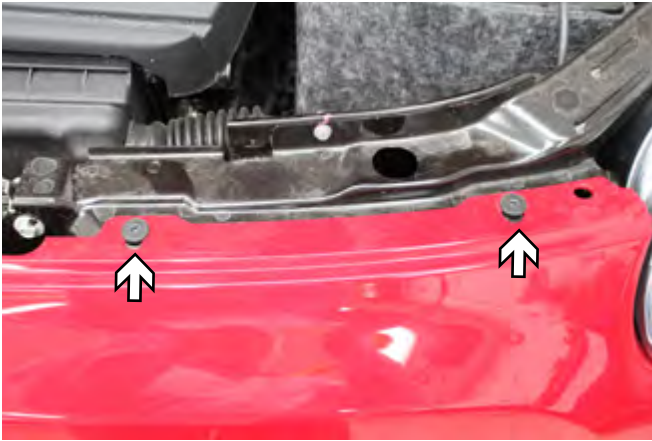

1. Using a T30 Torx, remove the four (4) screws from the top edge of the fascia. There are two (2) on each side.



2. Ahead of the front tire, use a Phillips screwdriver to remove three (3) screws. Do this to both sides of the vehicle.



3. Up in the corner, under the wheel well cover, use a T30 Torx to remove one (1) screw. Do this to both sides of the vehicle.



4. Using a Phillips screwdriver, remove one (1) screw from the bottom corner of the fascia. Do this to both sides of the vehicle.



5. Across the center on the underside of the vehicle, use a T30 Torx to remove three (3) screws. **DO NOT** remove the silver screw.

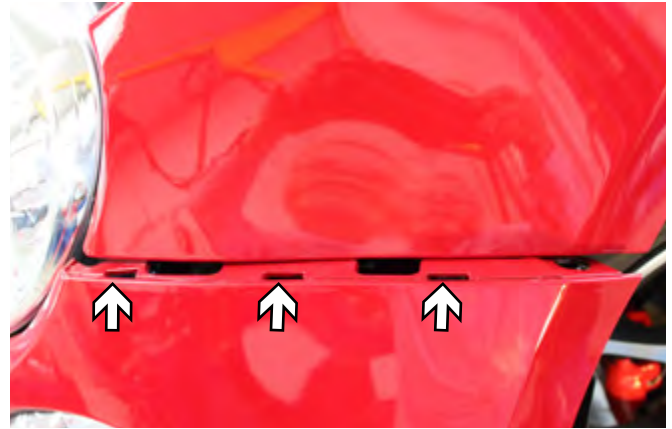

6. Unclip the fascia on the side. Once the fascia has been released, unplug the side marker light and running light.

Next, firmly pull the fascia outward to remove. Set the fascia aside on a flat, sturdy surface for reinstallation later.

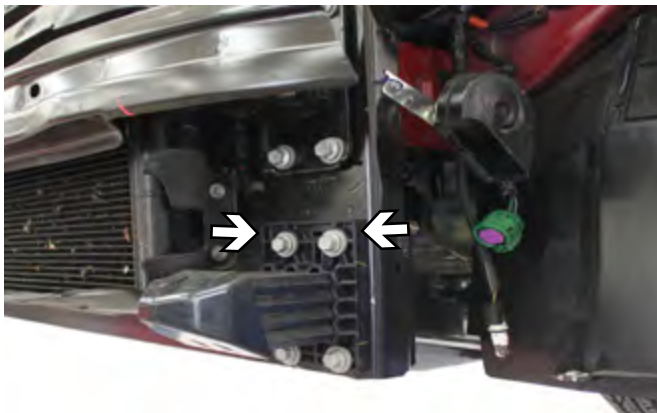

7. Use a 14MM socket to remove the four (4) lower bolts in order to remove the bumper bracket. This bracket will **NOT** be reinstalled.

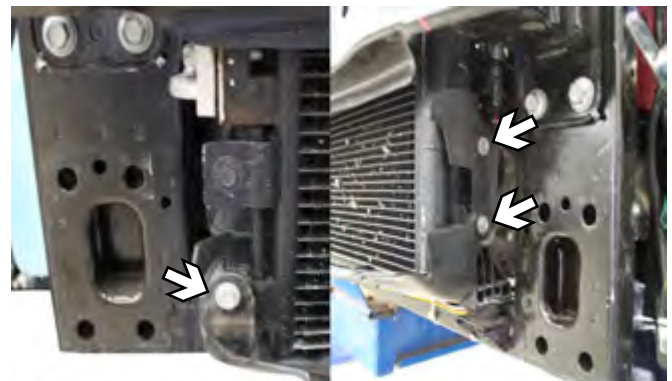

PASSENGER'S SIDE

DRIVER'S SIDE

8. In order to remove the air dam, use a 8MM socket to remove the two (2) bolts on the driver's side and the one (1) bolt on the passenger's side.



BX2801 2012 Fiat 500 Pop Installation Instructions

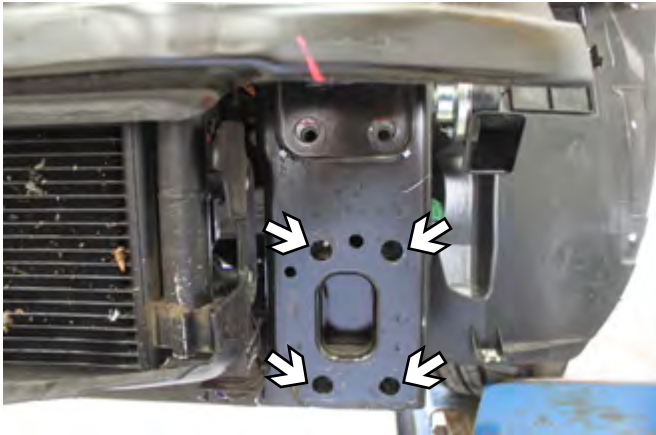

9. Align the baseplate with the four (4) holes and use the existing bolts to secure the baseplate. Do this on both sides of the vehicle.

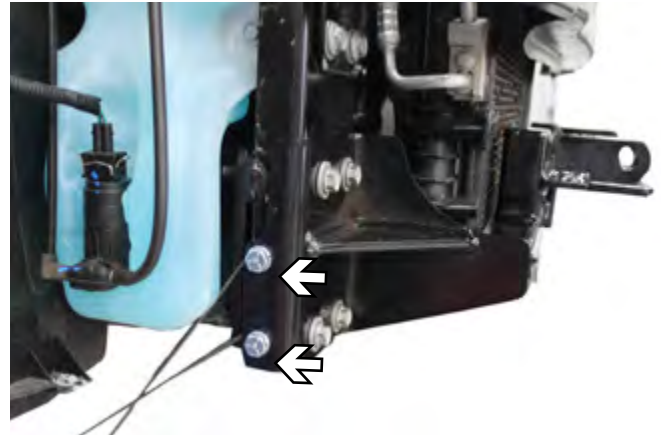

10. Using a 13/32" drill bit and the baseplate as a template, drill the two (2) side holes. Insert the 3/8"-16 x 1 hex head bolts, 3/8" lock washers and 3/8"-16 whiz nut weldments. Do this on both sides of the vehicle.



11. Possible location for BX8869 wiring kit: On the side of the tail light, using a T20 Torx remove the four (4) screws. Remove the back piece. Do this on both sides.



12. Possible location for BX8869 wiring kit: Using a 1/2" drill bit, drill a hole in the metal piece. Put the wires through the hole and silicon around it. Do this on both sides.

13. Attach the permanent baseplate safety cables to the provided convenience link on the baseplate. Additional options may interfere with suggested mounting; in this case, secure the cables to a solid piece of the frame as described in the instructions included with the permanent baseplate safety cables. Be sure the safety cables do not rub against any hoses or moving parts. Do this on both sides of the vehicle.



BX2801

2012 Fiat 500 Pop

Installation Instructions

CUSTOMER SERVICE COMMITMENT

Blue Ox is committed to providing you with exceptional customer care throughout your lifetime with our products. Our team is here to assist you with any questions you may have regarding the performance of your product. Simply call (402) 385-3051 and you can speak with our customer care team.

Additionally, please visit our website to see which rallies our Destination America team will be attending. For a nominal fee, our service technician will service your towing system to ensure it's in proper working condition. Also, as a commitment to our customers, should you visit our factory, you can stay at our full service Blue Ox campground at no charge along with enjoying a factory tour.

Again, thank you for being our customer and for the confidence you have shown in the performance of our products. It is because of customers like you we enjoy the success we have today.



© 2012 Blue Ox
One Mill Road, Industrial Park
Pender, Nebraska 68047
Phone: (402) 385-3051 • Fax: (402) 385-3360
www.blueox.com