



## INSTALLATION INSTRUCTIONS

1075 North Ave. Sanger, CA 93657-3539 toll free: 800-445-3767 web: www.belltechcorp.com

### 5556 REAR ANTI SWAY BAR KIT 86-97 NISSAN PICKUP

**Congratulations! You were selective enough to choose a BELLTECH PRODUCT. We have spent many hours developing our line of products so that you will receive maximum performance with minimum difficulty during installation.**

- Note: Confirm that all of the hardware listed in the parts list is in the kit. **Do not** begin installation if any part is missing. Read the instructions thoroughly before beginning this installation.
- Warning:** **DO NOT** work under a vehicle supported by only a jack. Place support stands securely under the vehicle in the manufacturer's specified locations unless otherwise instructed.
- Warning:** **DO NOT** drive vehicle until all work has been completed and checked. Torque all hardware to values specified.
- Reminder: Proper use of safety equipment and eye/face/hand protection is absolutely necessary when using these tools to perform procedures!
- Note: It is very helpful to have an assistant available during installation.

#### RECOMMENDED TOOLS:

- Properly rated floor jack, support stands, and wheel chocks
- Combination wrench set
- Torque wrench: *0-75 lb ft. range*
- Ratcheting socket wrench and socket sets
- Safety Glasses

#### KIT INSTALLATION

1. Open the hardware kit and remove all of the contents. Refer to the part list (Page 2) to verify that all parts are present.
2. Park the vehicle on a smooth level asphalt or concrete surface. Place a block in front of and behind the FRONT wheels. Jack up the REAR of the vehicle and place jack stands securely under the frame in the manufacturer's specified locations. Remove the rear wheels.
3. To determine the proper mounting position of the Anti-Sway Bar, lay the Anti-Sway Bar on a flat surface, so the end of the bar is held up by the swags, then place the Sway Bar so the ends of the bar point to the rear of the vehicle.
4. Thoroughly lubricate the **inside** of your new hyperthane bushings using the grease packet included with the kit. Place the bushings to the inside of the outermost bend on the Anti-Sway Bar. Refer to the diagram as to the proper bushing location.
5. Install the 3" U-clamps over the axle tubes and between the brake lines (Photo 1), making sure the brake lines are not clamped underneath. Carefully bend the hydraulic lines away from the rear end; place the flat plate and bushing bracket on the U-clamp and hand tighten one nut leaving the other side off for now.

6. Slide the bar over the axle and position the arms above the leaf springs. Set the bushings on the Sway Bar into the brackets (Photo 2), which you just assembled around the axle tube (see diagram).
7. Center the Anti-Sway Bar left to right and front to rear. The Anti-Sway Bar must be directly above the axle tube (Photo 3). Position the clamps in the position shown, do not position on atop the brake lines. The bar mounts on top of the axle towards the front. Torque all four nuts and washers on the U-bolts to 28-32 ft/lbs.
8. Directly in front of the ends of the Sway Bar are the mount holes in the frame (Photo 4). Install the end links, as shown (Photo 5). Torque the bolts to 40-45 ft/lbs.
9. NOTE: When installing the U-Clamps, make sure they are located between the brake lines and rear axle housing. The brake lines are attached to the rear axle with clamps. Bending the clamps back allows for some slight movement(freeing up) of the brake lines. Its very important that the brake lines do not interfere with the clamp assemblies.
10. Go over the entire installation procedure and make sure all the bolts and nuts are properly torques.

#### PART LIST FOR 5556 REAR ANTI SWAY BAR KIT

PART No.	DESCRIPTION	QTY.
5556-300	Rear Anti Sway Bar	1
113195	Pivot Bushing	2
114032	Bushing Bracket	2
114038	Under Support Plate	2
112258	3" Axle Clamp	2
110625	Flat Washer	4
113000	Grommet	8
112502	Cupped Washer	8
112138	3/8"-16 x 6 1/2" HHCS	2
110255	3/8-16 Nylock Nut	6
112422	2.5" Spacer Tube	2
110122	3/8-16 x 4 1/2" HHCS	2
6420-007	.5" Spacer Tube	2
55000-10	Grease Pack	1

The following instructions are essential to ensure your new bushings will have a long and trouble free life.

## **PRE-LUBRICATION**

- 1) **Lubrication of the bushing prior to** installation is important because the lubrication will greatly reduce bushing noise and it will increase the bushing life. Belltech recommends using the grease packet included in the kit. This will help protect the inside surface of the bushing and will last longer than most other types of grease. Thoroughly lubricate the inside of the bushing with this grease.
- 2) Make sure a maximum of 1/32" to 1/16" of the bushing is showing when you install it into the bracket. See the diagram below. If the bushing is showing more than 1/16" then use a belt sander or a sheet of coarse grit sand paper to shave it down to the proper height. In most applications you may refer to your original equipment Anti-Sway Bar to locate the proper place the new bushing belongs on your new Belltech Anti-Sway Bar.

Below is a detailed drawing of the complete end link that is used in this kit. Please note the orientation of the cup washers, making sure that when being assembled, that they cup each respective end link grommet.

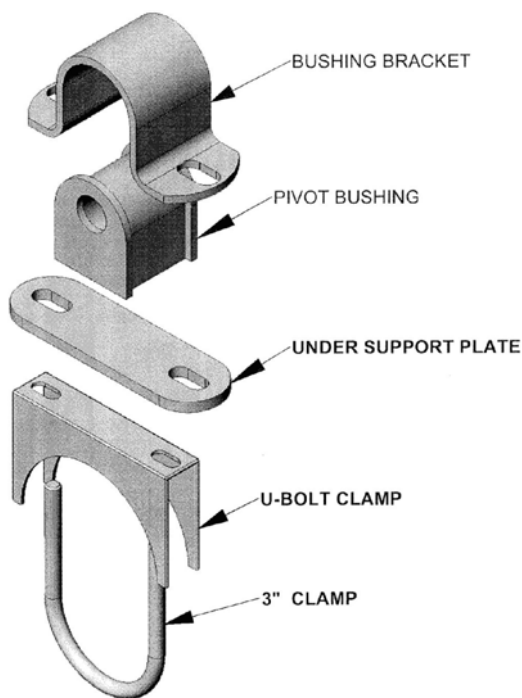

**U-CLAMP / BRACKET BUSHING ASSEMBLY**

**VIEW NOT TO SCALE**

USE THE .5" LONG SPACER TUBE  
ON LOWERED VEHICLES  
USE THE 2.5" LONG SPACER TUBE  
ON STOCK HEIGHT VEHICLES

USE THE 7" BOLT ON LOWERED VEHICLES  
USE THE 10" BOLT ON THE STOCK HEIGHT  
VEHICLES

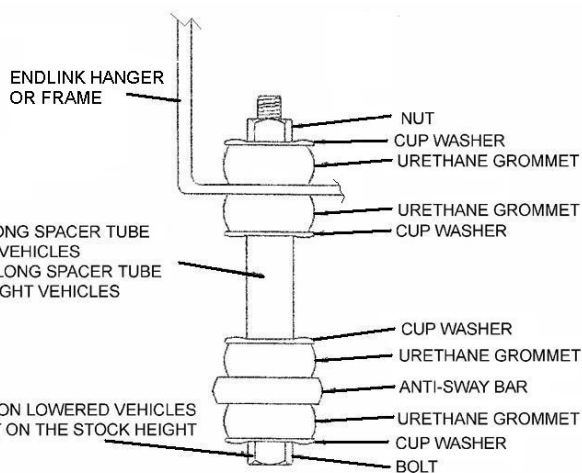

**ENDLINK ASSEMBLY**

**VIEW NOT TO SCALE**



**PHOTO 1**



**PHOTO 4**

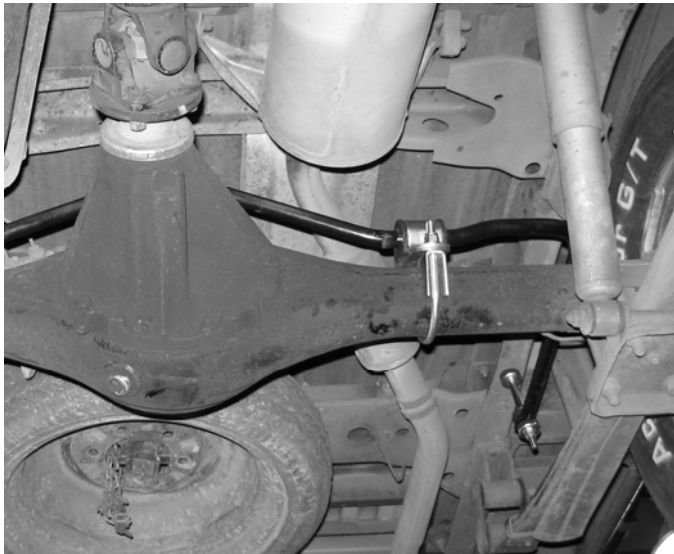

**PHOTO 2**



**PHOTO 5**

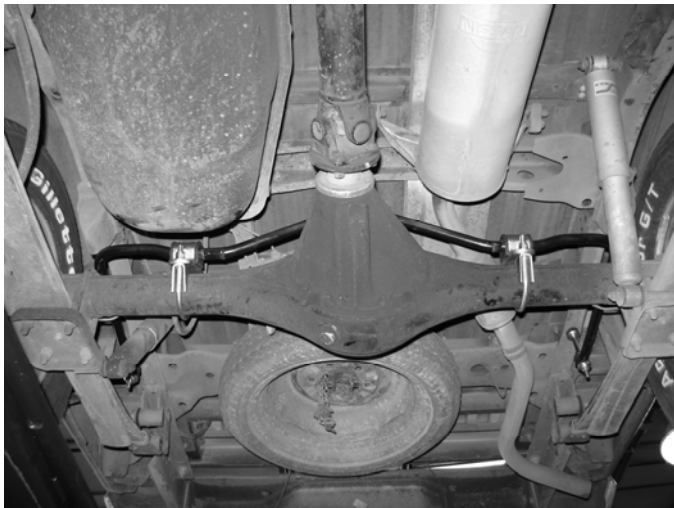

**PHOTO 3**



**PHOTO 6**