

# BAKFlip

BEST-SELLING HARD FOLDING COVER

G2 F1 FIBER MAX MX4

## INSTALLATION SHEET

Any damaged or missing parts?

Parts will be shipped to you directly.

Call 818-365-9000 Mon - Fri 8:30 am - 7:00 pm EST  
or email support@bakindustries.com

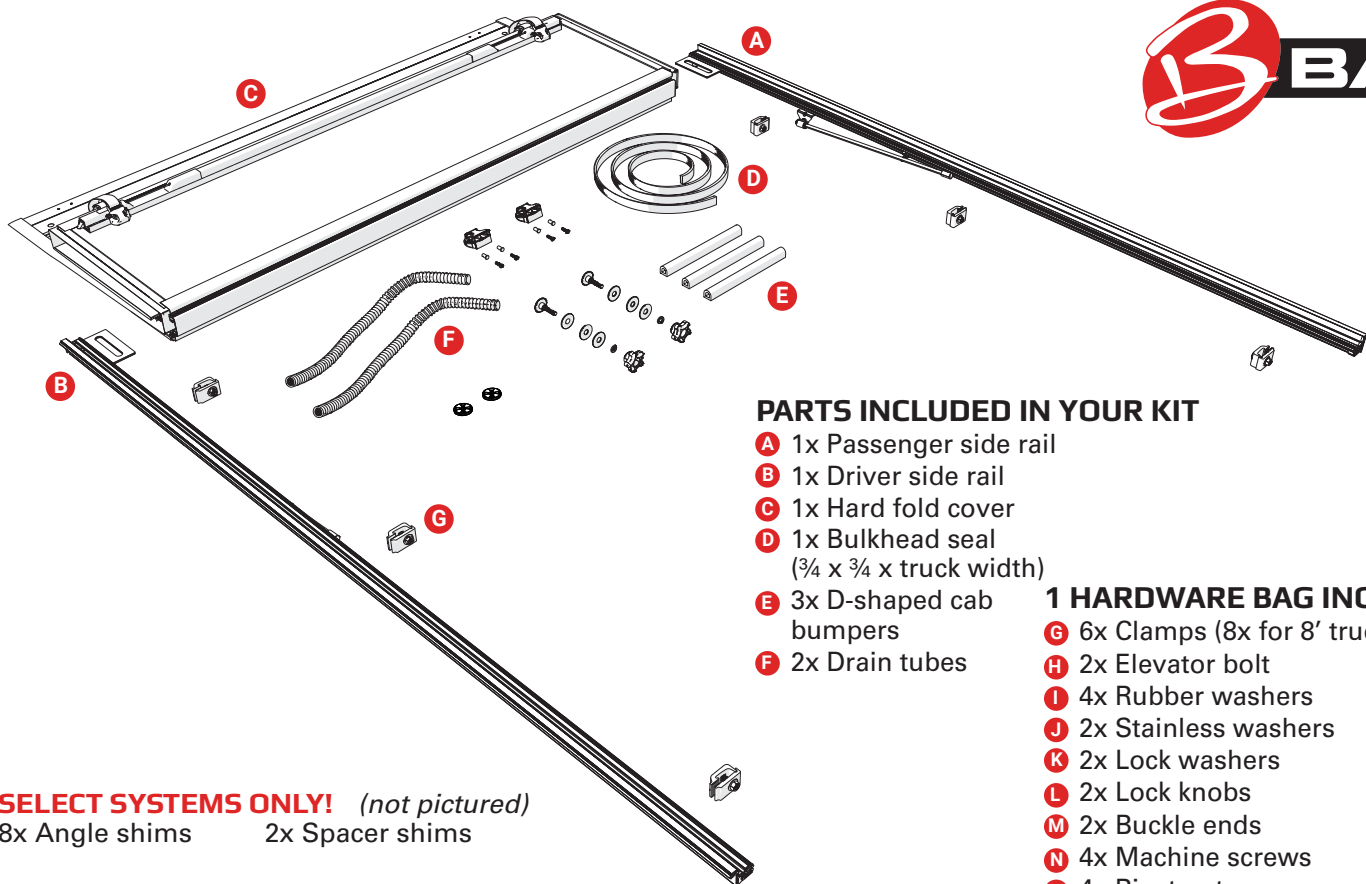

### PARTS INCLUDED IN YOUR KIT

- A 1x Passenger side rail
- B 1x Driver side rail
- C 1x Hard fold cover
- D 1x Bulkhead seal  
( $\frac{3}{4}$  x  $\frac{3}{4}$  x truck width)
- E 3x D-shaped cab bumpers
- F 2x Drain tubes

### 1 HARDWARE BAG INCLUDING

- G 6x Clamps (8x for 8' trucks)
- H 2x Elevator bolt
- I 4x Rubber washers
- J 2x Stainless washers
- K 2x Lock washers
- L 2x Lock knobs
- M 2x Buckle ends
- N 4x Machine screws
- O 4x Rivet nuts
- P 2x A-Panel spacer

**SELECT SYSTEMS ONLY!** (not pictured)  
8x Angle shims      2x Spacer shims

### TOOLS REQUIRED

- Scissors or utility knife
- 9/16" Wrench or socket
- Phillips screwdriver
- 7/8" Drill bit & drill

### TOOLS RECOMMENDED

- Blow dryer or heat gun

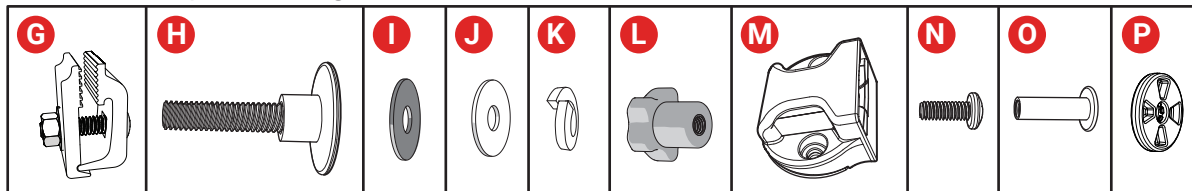

**1** Clean the top of the bulkhead to install the seal (D). Peel the backing and adhere the seal from one bedrail edge to the other. Remove any excess with scissors or a utility knife. If the truck has a drop-in bedliner, no seal will be needed.

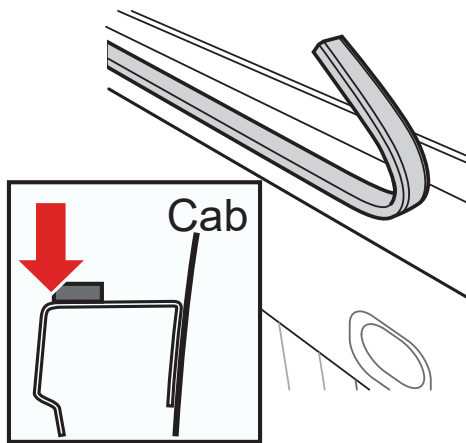

**2** Place passenger side rail (A) on the truck rail with the slotted bracket pushed all the way toward the cab and the bulkhead.

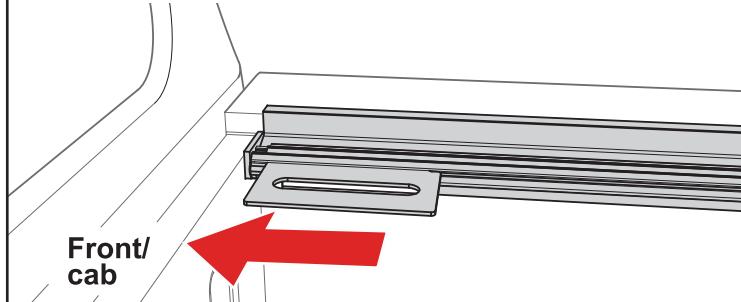

**NOTE:** Some drop-in bedliners may require trimming in the corners to fit the rail into the opening.

- 3** Make sure the rail is leveled as shown. Place one clamp (G) onto the rail, approximately 12" from the end nearest the cab. Hand tighten to 10 ft/lbs of torque with a 9/16" wrench or socket. Apply downward pressure to the cover rail when tightening the clamps to ensure that the rail sits flush and the seals are set.

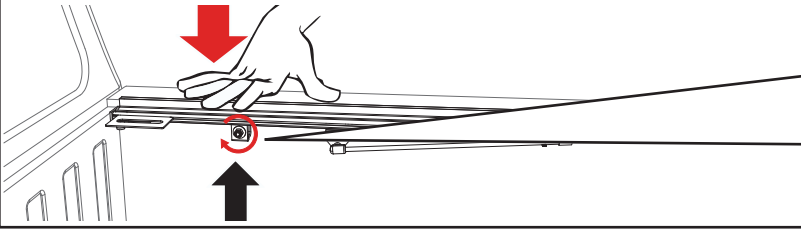

**NOTE:** When installing each clamp, make sure that the clamps are inserted as far up onto the rail as possible and that the clamp teeth fit squarely and fully engage the ribs of the cover rail.

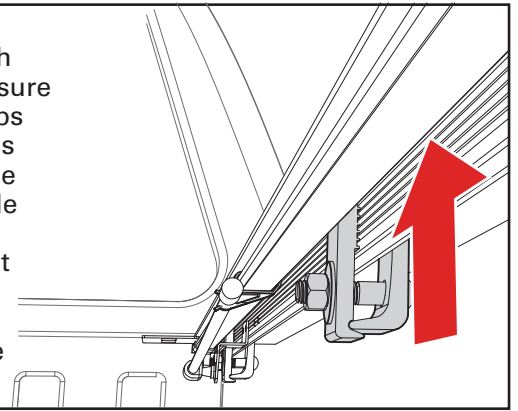

- 4** Place the second clamp (G) near the center of the rail. For 8' beds two clamps will need to be evenly spaced in the center section of the rail. Hand tighten to 10 ft/lbs of torque with a 9/16" wrench or socket.

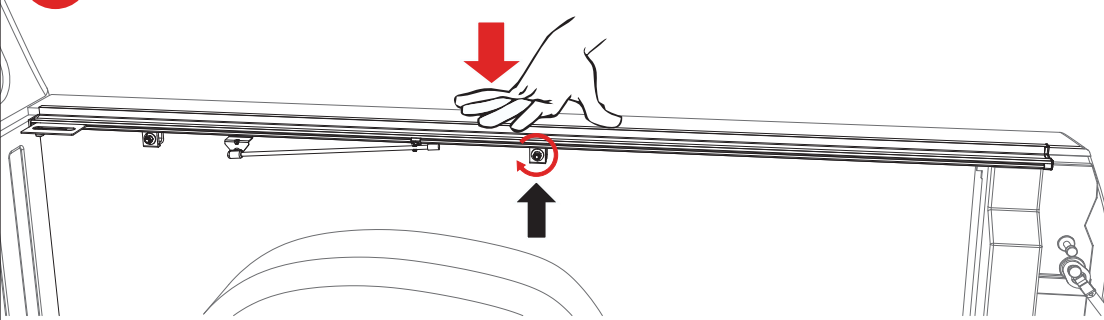

Always apply downward pressure to the cover rail when tightening the clamps to ensure that the rail sits flush and the seals are set.

**CAUTION:** overtightening the clamps could cause warping of the truck bed covers.

- 5** Place the third clamp (G) near the rear of the rail, approximately 12" from the tailgate. Hand tighten to 10 ft/lbs of torque with a 9/16" wrench or socket. **Repeat steps 2-5 on the driver's side rail (B).**

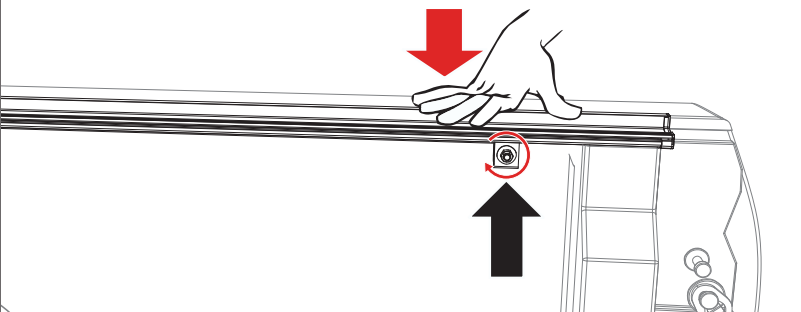

- 6** Set the truck bed cover (C) in the folded position on the rails towards the front of the cab.

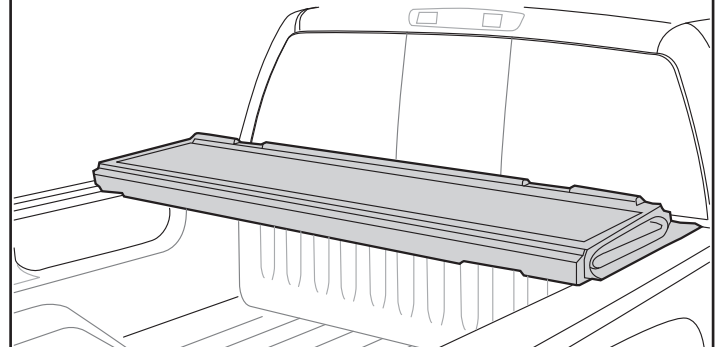

- 7** Position the buckle ends (M) so the open side faces the bed cover panel. Use a screwdriver to install the two buckles into the pre-drilled holes on the front header panel with the provided machine screws (N) and rivet nuts (O). **DO NOT use a screw gun, securely tighten by hand only.**

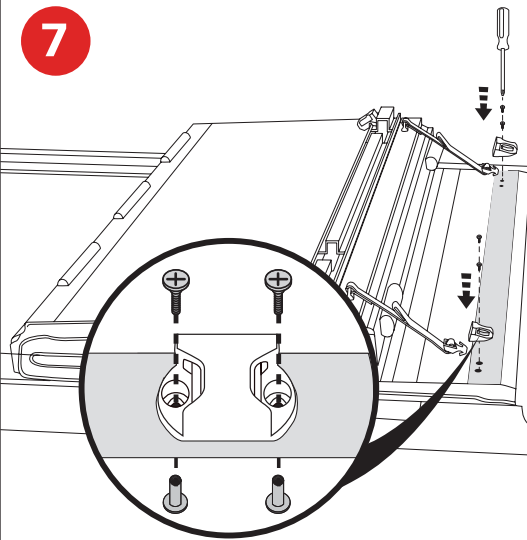

- 8** The cover's small panel faces toward the cab and folds down over the slotted rail brackets. The front panel must sit just inside the bulkhead rail with the seal resting on top of the bulkhead. Adjust the panel down so it sits squarely on the rails and align the mounting holes with the slotted rail brackets.

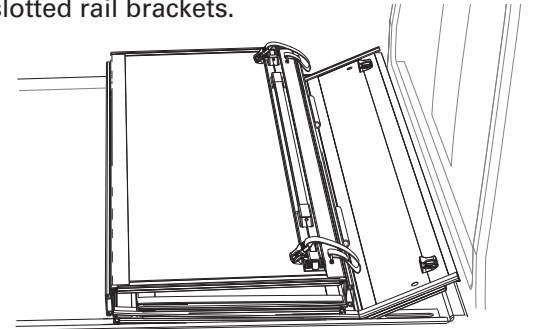

**NOTE:** Remove all foam packing before proceeding.

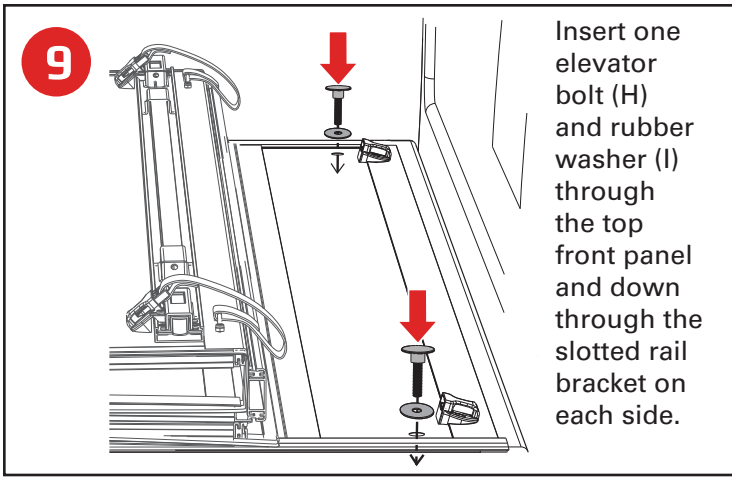

Insert one elevator bolt (H) and rubber washer (I) through the top front panel and down through the slotted rail bracket on each side.

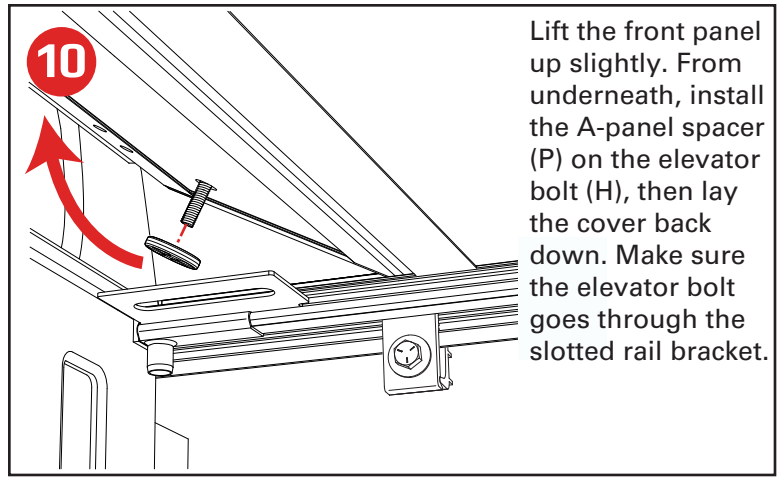

Lift the front panel up slightly. From underneath, install the A-panel spacer (P) on the elevator bolt (H), then lay the cover back down. Make sure the elevator bolt goes through the slotted rail bracket.

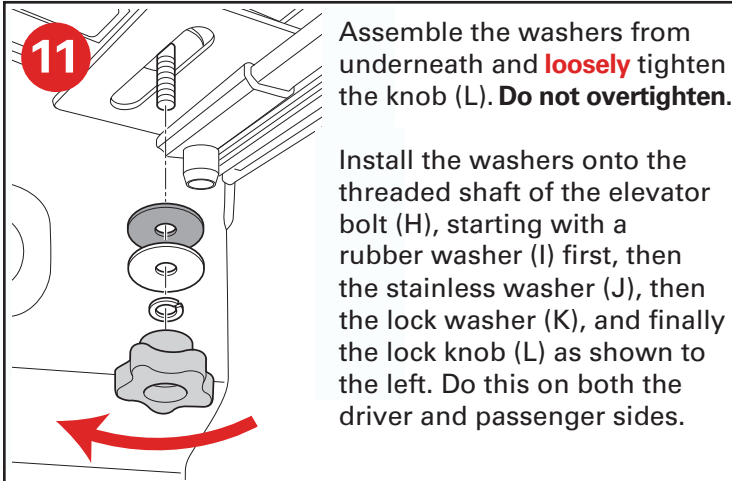

Assemble the washers from underneath and **loosely** tighten the knob (L). **Do not overtighten.**

Install the washers onto the threaded shaft of the elevator bolt (H), starting with a rubber washer (I) first, then the stainless washer (J), then the lock washer (K), and finally the lock knob (L) as shown to the left. Do this on both the driver and passenger sides.

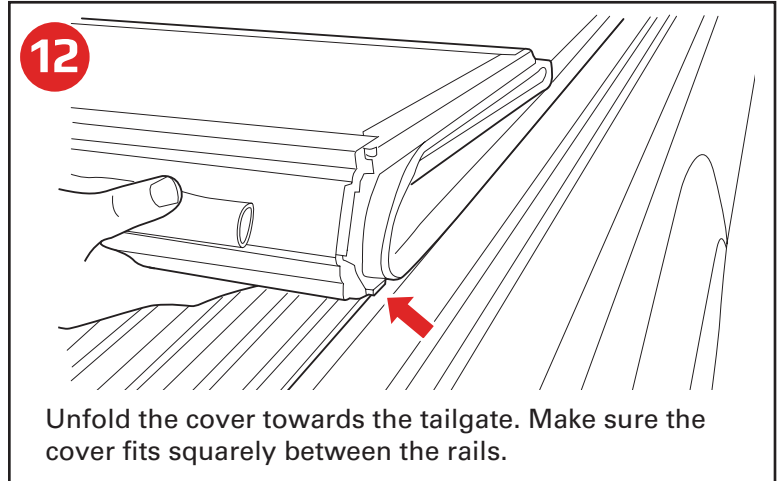

Unfold the cover towards the tailgate. Make sure the cover fits squarely between the rails.

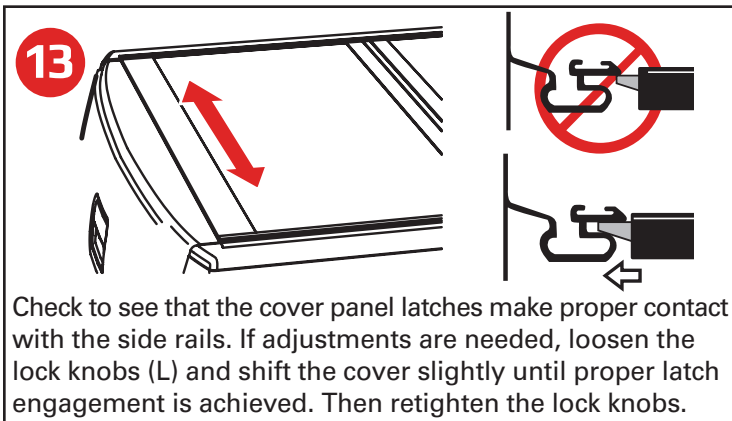

Check to see that the cover panel latches make proper contact with the side rails. If adjustments are needed, loosen the lock knobs (L) and shift the cover slightly until proper latch engagement is achieved. Then retighten the lock knobs.

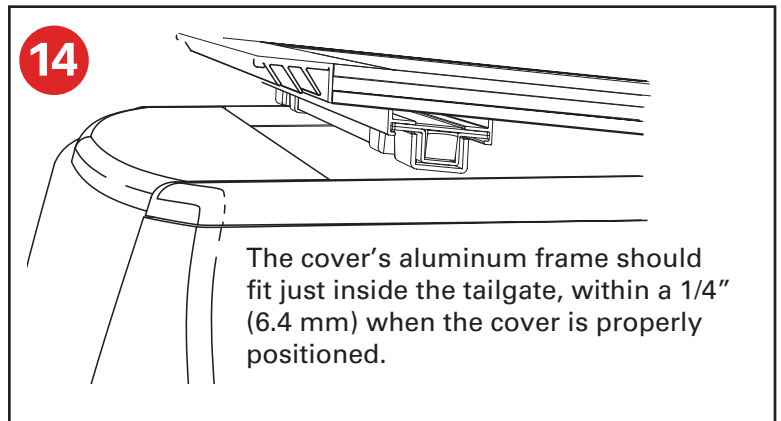

The cover's aluminum frame should fit just inside the tailgate, within a 1/4" (6.4 mm) when the cover is properly positioned.

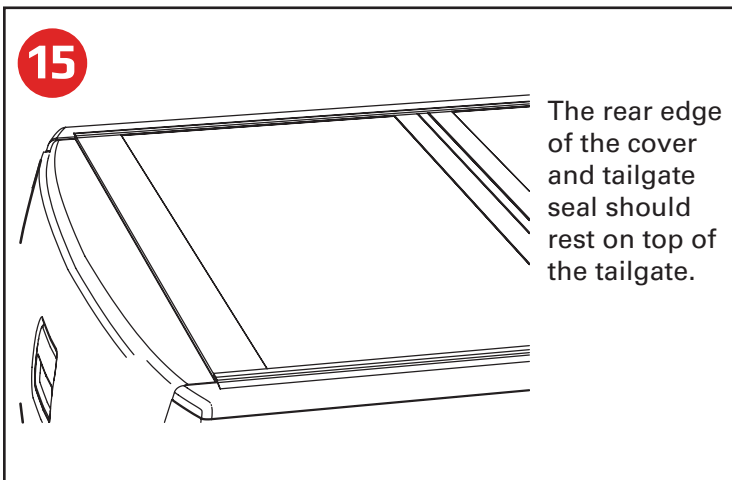

The rear edge of the cover and tailgate seal should rest on top of the tailgate.

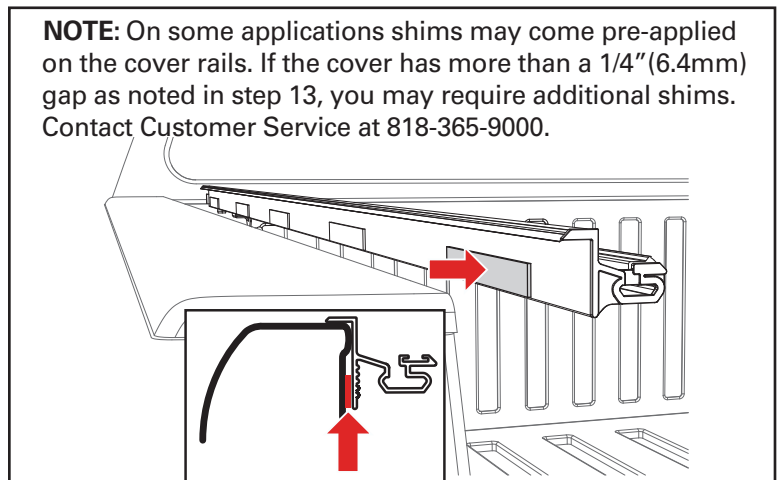

**NOTE:** On some applications shims may come pre-applied on the cover rails. If the cover has more than a 1/4" (6.4mm) gap as noted in step 13, you may require additional shims. Contact Customer Service at 818-365-9000.

**IMPORTANT:** In order for the cover to operate properly the cover rails **MUST** be square (90° angle) to the truck bed rails. This allows the rear latch to engage accurately.

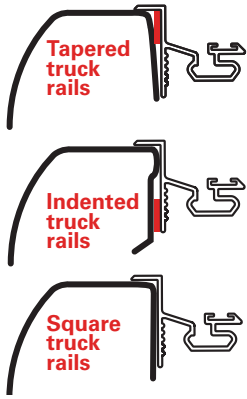

Please find your truck style to the left to see how shims are pre-applied to achieve a level bed rail on different trucks.



**Do NOT** tilt rails

**16**

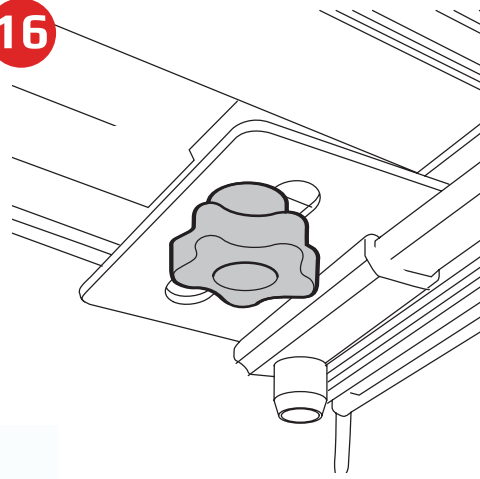

Once the cover is positioned correctly, fold the cover over toward the cab and tighten the knobs (L) until the lock washer (K) flattens out and locks the knob securely to the bracket.

**17**

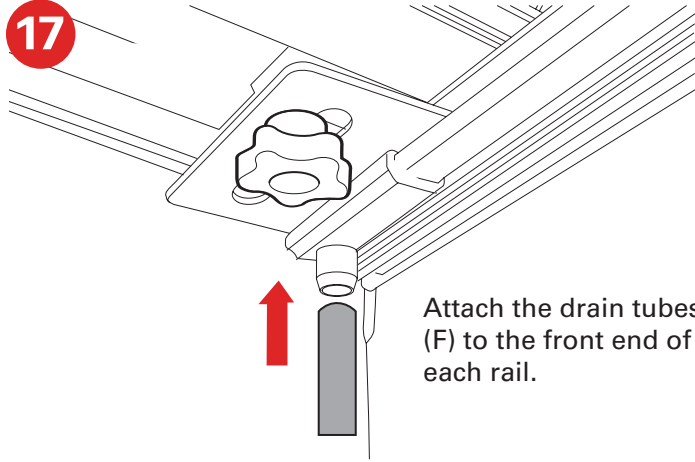

Attach the drain tubes (F) to the front end of each rail.

**18**

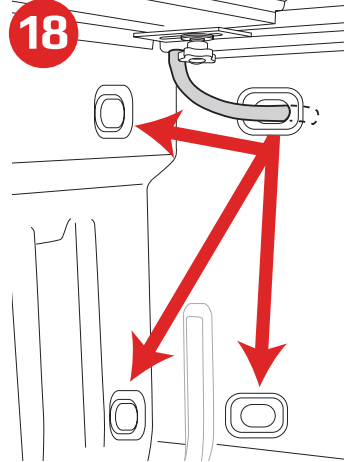

Route the other end of the drain tube (F) through the factory bed plug. Simply remove these plugs or drill a 7/8" hole through the plastic. Alternately, the plug can be trimmed using a utility knife making sure to cut a hole large enough to not crimp the drain tube. **NOTE:** If you have a drop-in bedliner, simply run the drain tubes behind or under the liner.

**19**

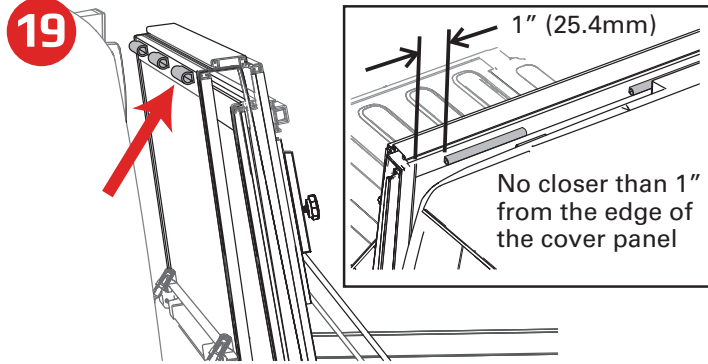

No closer than 1" from the edge of the cover panel

With the bed cover in the folded position, install the three D-shaped cab bumpers (E) along the top edge of the cover where it meets the truck cab.

**20**

If the side seals of the cover appear wrinkled, exposure to the sun will assist the seals to lay flat. Applying heat with a hair dryer or carefully with a heat gun will also smooth the seals.

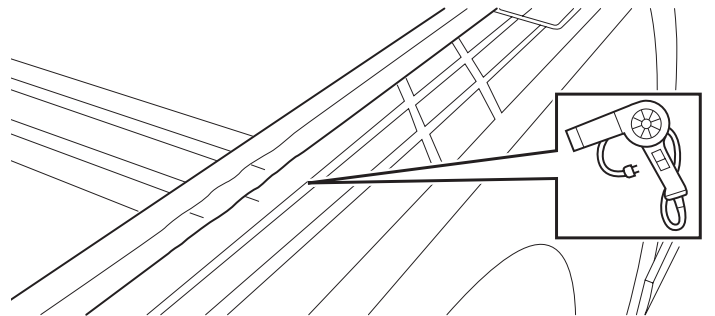



# IMPORTANT Safe operation and use

## IMPORTANT NOTICE

While driving, cover must be completely flat and secure with all latches in the closed position OR completely folded up (all panels) and secured at the cab. DO NOT DRIVE with cover partially opened.

### Tonneau Cover Positions While Operating Vehicle

Prior to vehicle operation, the tonneau cover MUST be properly secured.

#### CLOSED POSITION

All panels must be closed and FULLY LATCHED to passenger & driver side rails (A & B). All panels must be flat and latches engaged.

#### FOLDED UP POSITION

To drive with your cover in the folded up position, simply make use of the provided tie-down straps and buckles provided with your cover. Ensure BOTH buckle clips are fully inserted into the buckle ends (O) located on the front header panel of the cover and adjust the straps to ensure the cover is secure during vehicle operation. The clips should be secured in the storage position, as shown in **Figure 1**, when not in use.

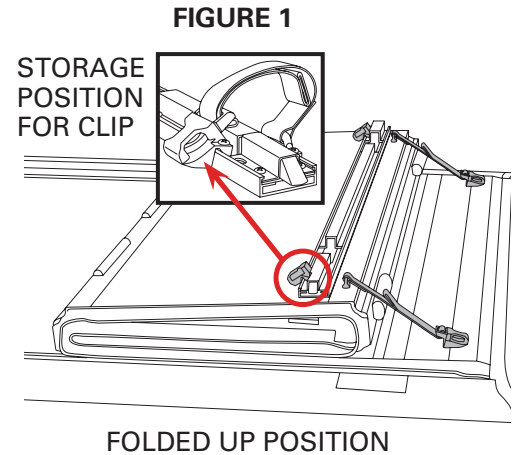

#### FLIPPED UP POSITION

1) Fold the cover open and lift it until it's vertical or past 90 degrees towards your truck cab. Then release the prop rod (G) that is attached to your rail. Fold the prop rod over and position it firmly against the vertical plate on the underside of your cover. Then slide the prop rod locks downwards and tighten the knobs to lock into position. Do this on both sides of the cover.

2) Your cover should be firmly in position with little to no movement once the prop rods (G) are locked.

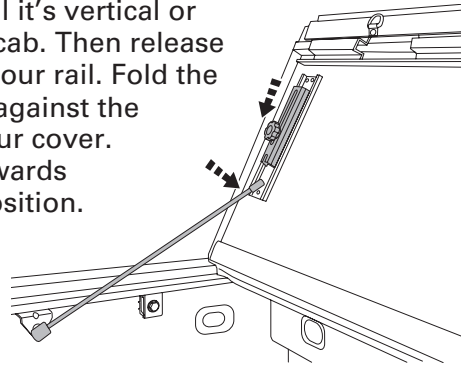

FLIPPED UP: 1

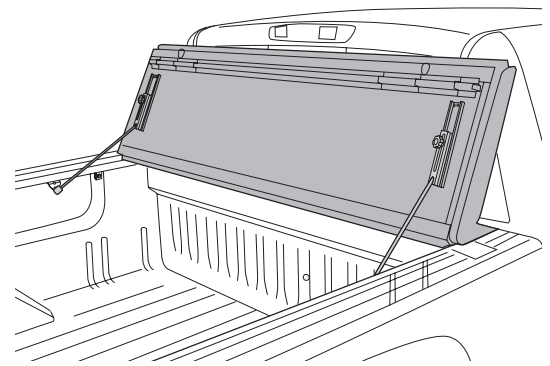

FLIPPED UP: 2

### Tail Panel Operation

#### TO CLOSE THE TAILGATE PANEL

■ The tailgate can be closed with the cover either up or down for universal operation.

#### TO OPEN THE TAILGATE PANEL

- Open the tailgate and reach under the panel for the cable at the ends of the panel housing.
- Pull down on either cable to release both rear latches with one hand while lifting the panel with the other hand.

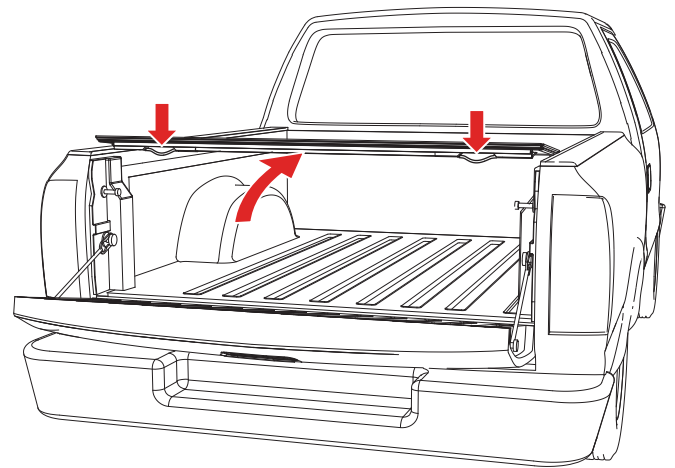

**DO NOT ATTEMPT TO DRIVE WITH THE TAIL PANEL IN THE PARTIALLY OPEN POSITION!**



Remove any snow or foreign matter before folding the bed cover.



Do NOT allow the vehicle to be towed backwards without first removing the cover from the vehicle.

# Warranty

BAK® Industries ("BAK") warrants your BAKFlip Hard Folding Cover to be structurally free from defects in material and workmanship for the period as outlined in the table below from the retail date of purchase. Warranty registration must be on file and/or proof of original purchase (detailed and dated receipt) required for warranty service. Warranty is nontransferable and applies to the original purchaser of the BAK product only.

PRODUCT	WARRANTY PERIOD	<b>REGISTER YOUR WARRANTY NOW AT BAKINDUSTRIES.COM</b>	
BAKFlip G2	3 Year Limited Warranty		
BAKFlip F1	5 Year Limited Warranty		
BAKFlip FiberMax	3 Year Limited Warranty		
BAKFlip MX4	5 Year Limited Warranty		

BAK reserves the right to determine whether a product needs to be repaired or replaced. No labor or service allowance is given or implied. The warranty will be void if the product has been damaged by accident, unreasonable use, neglect, improper service/installation/removal, modifications, acts of God or normal wear and tear or other causes not arising out of defective materials or workmanship. BAK assumes no liability for injury, loss, incidental or consequential damages. BAK reserves the right to substitute an entire replacement system or provide other remedies than those listed in this warranty for discontinued products or other reasons. Shipping charges will apply for any repair or replacement.

BAK is committed to providing you with our best service at all times. Please feel free to contact us should you require any assistance with your BAK product.

## CARE AND MAINTENANCE

BAKFlip tonneaus are made from durable materials and require simple care to ensure a long life of performing well and looking great.

### Cleaning the Top (Washing)

Standard automotive soap and water with a soft sponge or cloth are recommended for cleaning. Shabby dry to keep the finish polished and brilliant. Wax is NOT recommended as it tends to fill in cracks and crevices, which may affect the textured panel finish. Do NOT use any harsh cleaners or abrasives.

### Maintenance

It is recommended that you periodically check your cover is securely attached to your truck bed. Inspect the clamps and front mounting bolts to ensure they were properly installed and have not come loose or knocked out of adjustment during operation. Covers that are used with high frequency or that are subject to the vibrations and impact from rough roadways can cause the cover to require adjustment.

### Lubricating the Latches

It is recommended that you periodically inspect and service the latches on each panel. Clean away any excess dirt or grime and lubricate with silicone spray. Ensure the latches move freely in and out to properly engage the side rail and provide proper performance with optimum security. Be careful not to overspray the cover. Wipe away any excess around the latch location.