

AMP RESEARCH Power Step

MADE IN USA

APPLICATION	MODEL YR	PART #
Chevy Tahoe / GMC Yukon / Cadillac Escalade *	2007 - 2014	75125-01A
Chevy Suburban / GMC Yukon XL / Escalade ESV	2007 - 2014	75125-01A
Chevy Avalanche / Escalade EXT	2007 - 2014	75125-01A

*Modification required to running board assembly. See Item 1 on page 2.

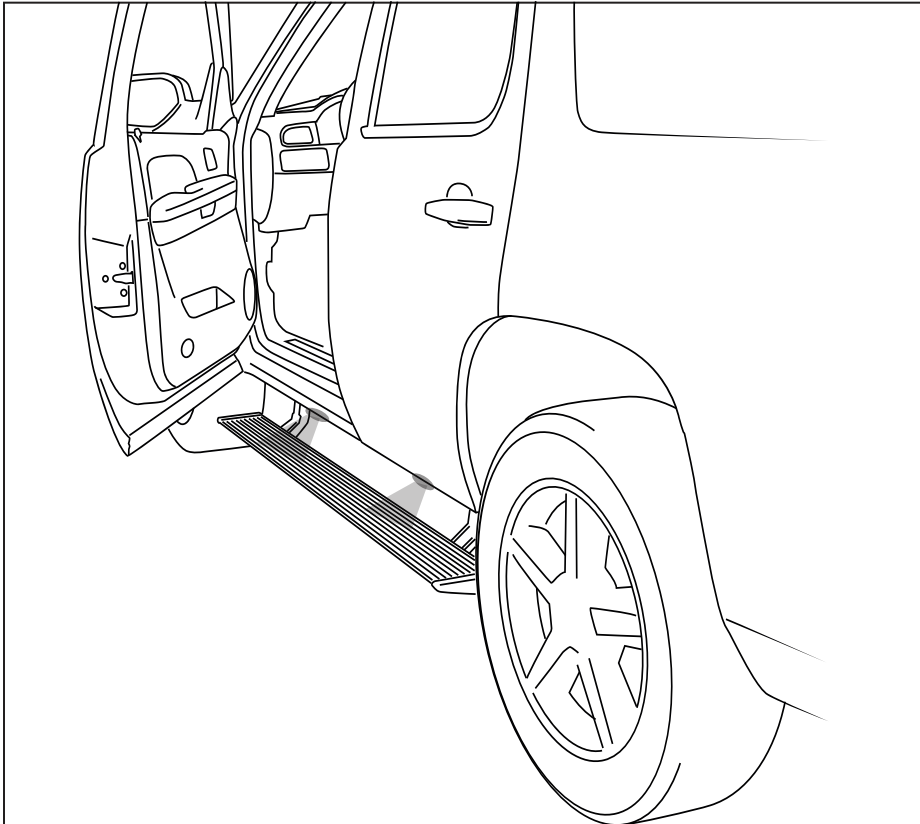

INSTALLATION TIME

3-5 Hours

Professional installation recommended

SKILL LEVEL



4= Experienced

TOOLS REQUIRED

- Safety goggles
- Measuring tape
- Flat blade screwdriver
- Phillips head screwdriver
- Right angle drill
- 9/32" drill bit
- 13 mm socket
- 10 mm socket
- 7 mm socket
- Ratchet wrench and extension
- 13mm end wrench
- Wire stripper / cutter
- Pliers
- Corrosion inhibitor
- 3/16" hex key wrench (allen wrench)
- 5mm hex key wrench (allen wrench)
- Electrical tape
- Weather proof caulking (silicone sealer)

WARRANTY

5-Year Limited Warranty

AMP RESEARCH TECH SUPPORT 1-888-983-2204 (Press 2) Monday - Friday, 6:00 AM - 5:00 PM PST

Invented, engineered and manufactured exclusively by AMP Research in the USA. May be covered by one of the following patents: 6,641,158; 6,830,257; 6,834,875; 6,938,909; 7,055,839; 7,380,807; 7,398,985; 7,584,975 ©2012 AMP Research. All rights reserved. Printed in USA.

Note: Some Applications require modification.

Application	Cut Length
Suburban, Yukon XL, Avalanche, Escalade EXT/ESV	79" (No Modification Required)
Tahoe, Yukon, Escalade	72" (Trim 7")

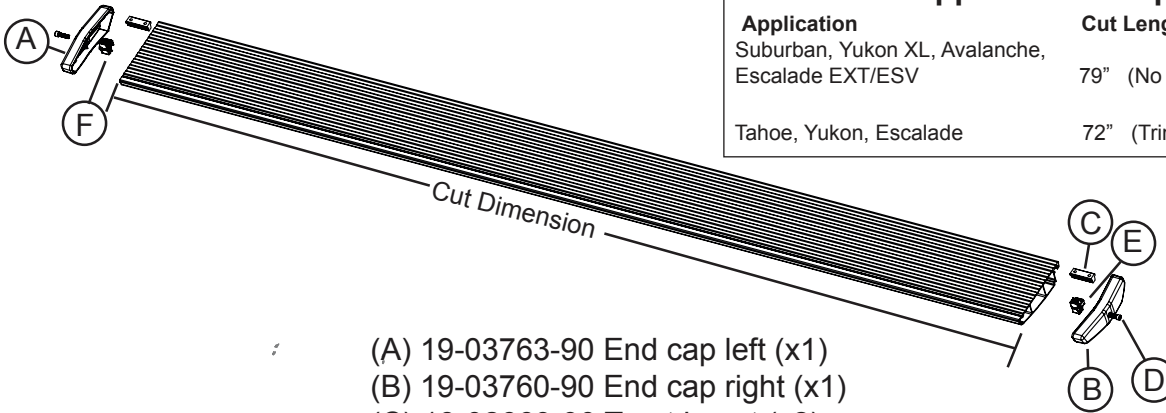

- (A) 19-03763-90 End cap left (x1)
- (B) 19-03760-90 End cap right (x1)
- (C) 18-02663-90 T-nut insert (x2)
- (D) 19-02802-90 Socket cap screw (x2)
- (E) 19-03761-90 End cap wedge right (x1)
- (F) 19-03764-90 End cap wedge left (x1)

① x2

Running board assembly

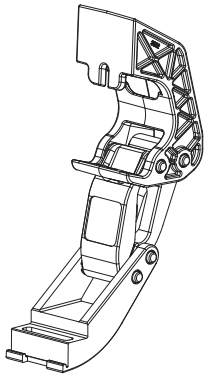

② x2
10-03273-10
Idler linkage assembly

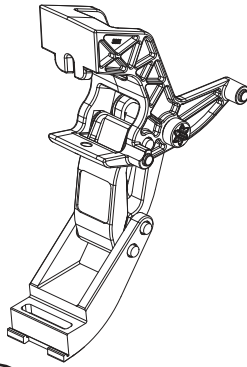

③ x2
10-03272-10
Motor linkage assembly



④
19-03348-90L
Wire harness

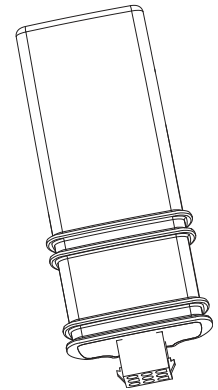

⑤
19-03297-A06
Controller

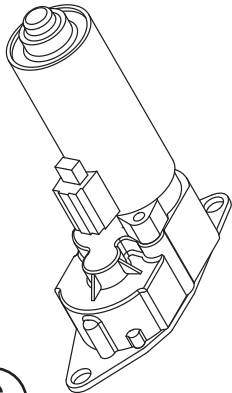

⑥ x2
20-03289-93
Motor

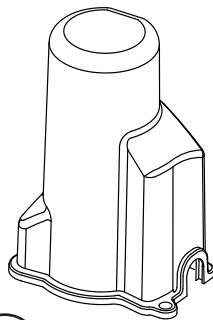

⑦ x2
19-03238-90
Motor Cover

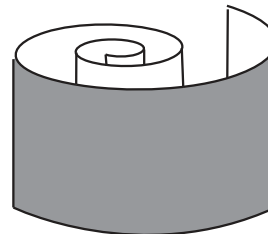

⑧
19-03403-90
Rubber

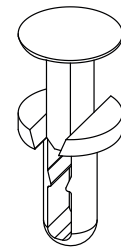

⑨ x6
19-02721-90
Cinch Fastener

PARTS LIST AND
HARDWARE
IDENTIFICATION

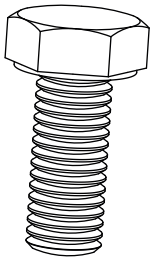

10 x4
19-02849-90
Hex Bolt

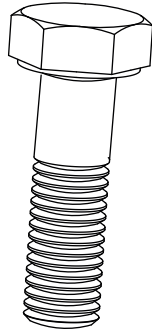

11 x4
19-03326-90
Hex Bolt

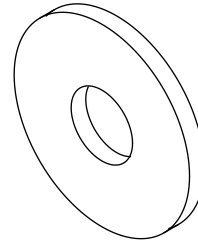

12 x4
19-02389-90
Washer



13 x4
10-00115-60
Nylock Nut

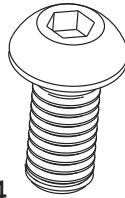

14 x4
16-02634-90
Button Head Bolt

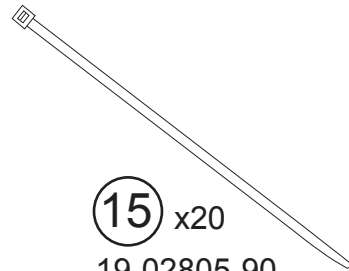

15 x20
19-02805-90
Cable tie (7")

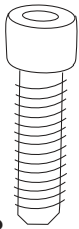

16 x8
19-02802-90
Socket Cap Screw

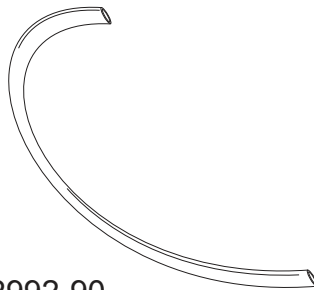

17
19-02992-90
Tubing (Installation Tool)

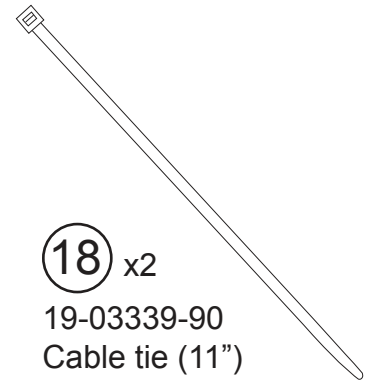

18 x2
19-03339-90
Cable tie (11")

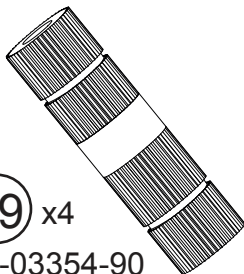

19 x4
19-03354-90
Posi-Tap™

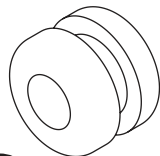

20
19-02640-90
Grommet

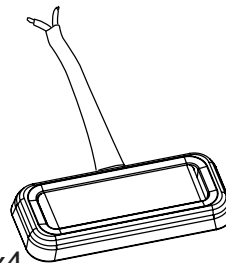

21 x4
19-03302-90
LED Lamp

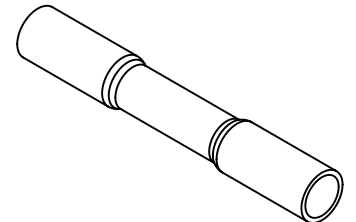





22 x8
19-03911-90
Butt Connector

AMP RESEARCH Power Step

MADE IN USA

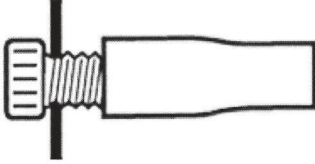
WIRING GUIDE / General Instructions

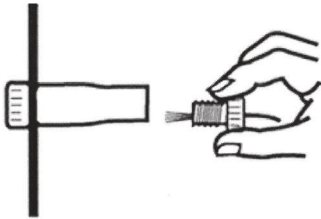
Posi-Tap™ installation instructions

 <p>1. Insert</p>	 <p>2. Tighten</p>	 <p>3. Strip 3/8"</p>
 <p>4. Insert & Tighten</p>	 <p>For two or more wires twist.</p>	<p>Posi-Tap™ Patents: 5,228,875; 5,695,369; 5,868,589, 2,708. Other patents pending</p>

CAUTION

- Handle the motor and linkage assemblies with care when installing. Dropping can damage motor.
- Remove fuse from wiring harness during installation. Failure to do so could result in severe electrical shock.

AMP RESEARCH TECH SUPPORT 1-888-983-2204 (Press 2) Monday - Friday, 6:00 AM - 5:00 PM PST

Designed and manufactured by AMP Research. Patent 6,830,257 / 6,641,158 / 6,834,875 / 6,938,909 / 6,942,233 / 7,007,961 Other US and worldwide patents pending. 5-year limited warranty. Professional installation is recommended.

Bolt idler linkage assembly to rearmost mounting tab using an M8 nut and washer (some vehicles may require a M8 x 35 bolt) and a M8x16 Button Head Screw. Install threaded clamping plate (13) on top of pinch weld and thread fastener (14) into clamping plate and finger tighten. Install fastener (12), finger tighten only. Next tighten fastener (14) to 16 ft-lbs. (22N m). Install threaded clamping plate (13) on top of pinch weld and thread fastener (10) into clamping plate and finger tighten. Install fastener (12), finger tighten only. Next tighten fastener (14) to 16 ft-lbs. (22N m).

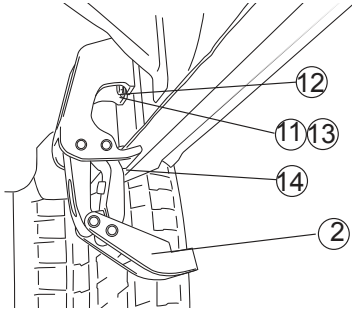

1

Bolt driving linkage assembly to forward most mounting tab using an M8 nut and washer (some vehicles may require a M8 x 35 bolt) and a M8x16 Button Head Screw.

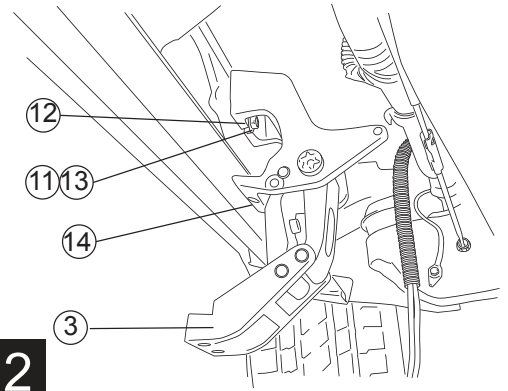

2

Slide mounting T-nut into position. Mount board and tighten fasteners to 10 ft-lbs. Align the end of the board with the rear edge of the back door.

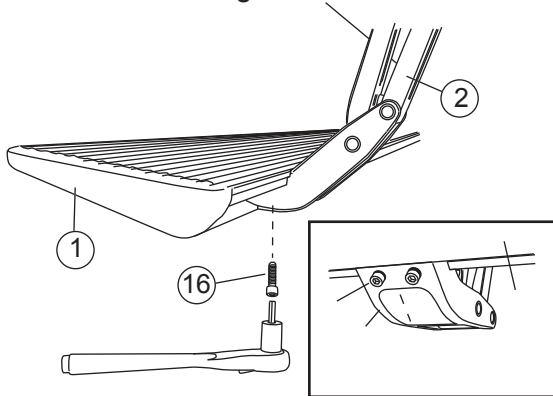

3

Tighten button head fasteners and M8 nuts on driving and idler linkages to 16 ft-lbs.

On some vehicles the emergency cable bracket may come in contact with linkage arm. If so, wrap supplied rubber around bracket and secure with two cable ties.

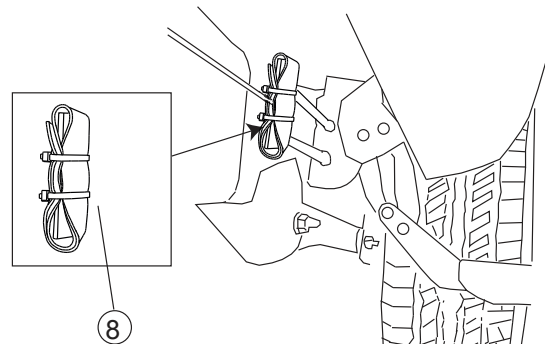

4

Using the two 11" cable ties, mount controller to support arm next to battery

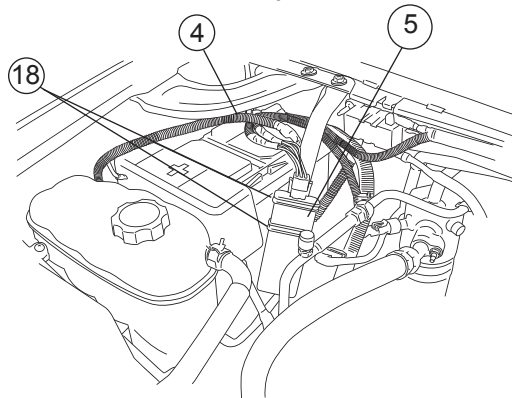

5

Plug in wire harness. (Ensure that locking tabs engage.)

Remove power fuse. Attach power lead (RED wire) to positive pole on the battery.

CAUTION: Do not ground wrench when engaged with nut.

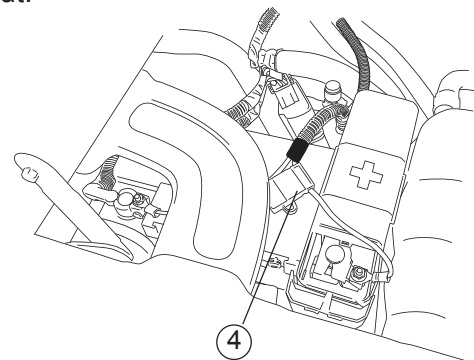

6

Attach ground lead to negative battery pole.

Route long end of wire harness above engine and down through drivers side wheel well. Zip tie harness to cowling clips on fire wall. Route short end down passengers side.

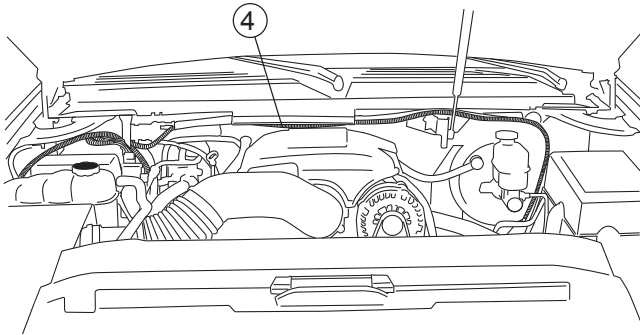

7 Secure with zip ties.

Route wire harness along the frame. Secure with zip ties.

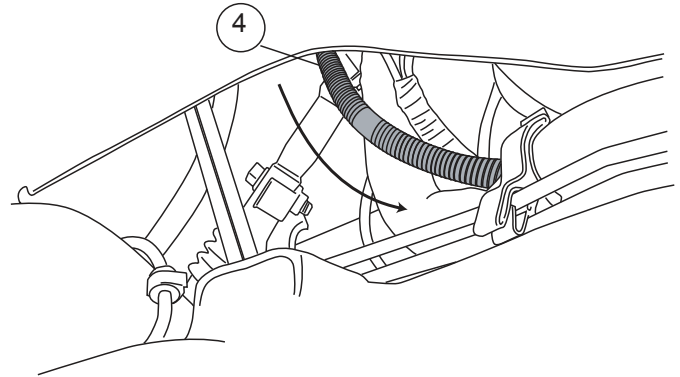

8

Poke hole through rubber grommet near front door on underside of floor panel with small phillips screwdriver. Push both wires through hole. (See Step 11 for passenger side notes.)

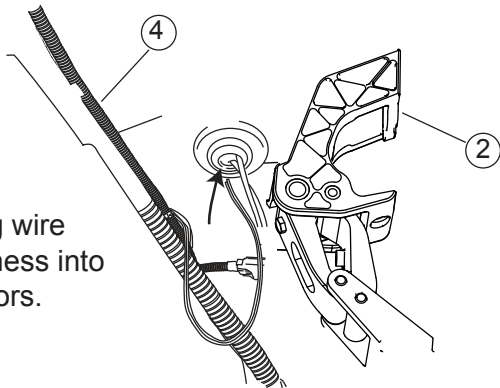

Plug wire harness into motors.

9

Pop off the threshold cover with screwdriver and remove the kick panel. The panel will slide out from under the seat after fasteners give way.

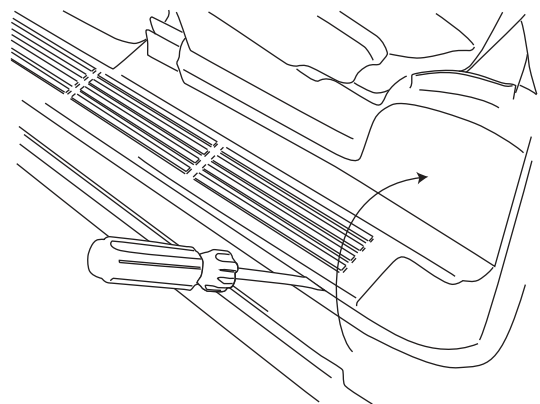

10

Pull up the carpet and thread both wires through the floor panel (same steps on passenger side EXCEPT drill 9/32" hole in metal and add rubber grommet).

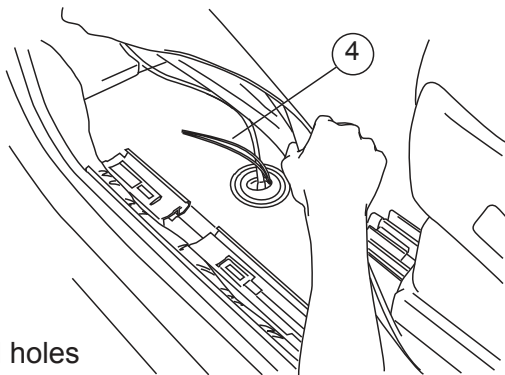

Seal holes with silicon glue.

11

Locate wire loom in door sill. Carefully remove wire wrap and find the trigger wire.

Drivers side: LIGHT BLUE wire with BLACK STRIPE

Passenger side: GREEN wire with BLACK STRIPE. (Locate wire rearward of junction shown in step 13)

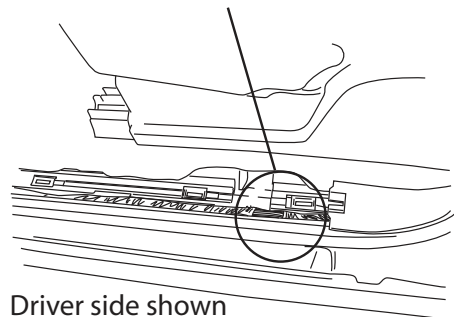

Driver side shown

12

Using Supplied Posi-Tap™ connector, splice shorter trigger wire into wire found in Step12.

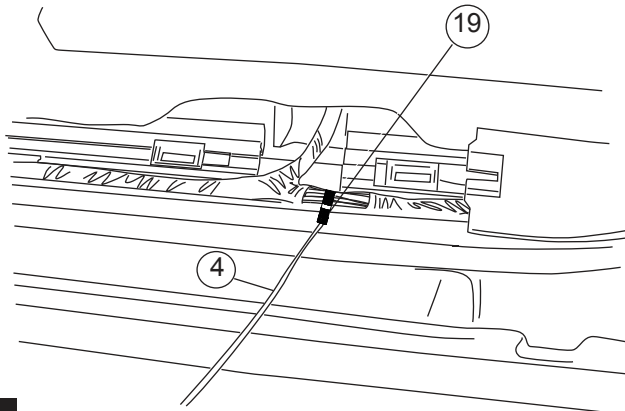

13

Remove plastic trim on door near mirror attachment.

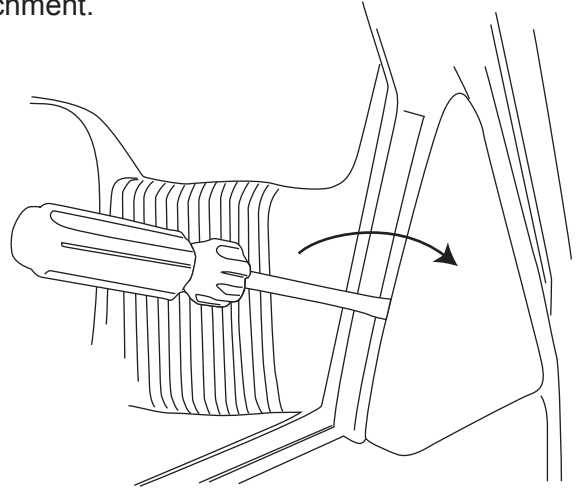

14

Carefully pry up window/ door lock switch plate

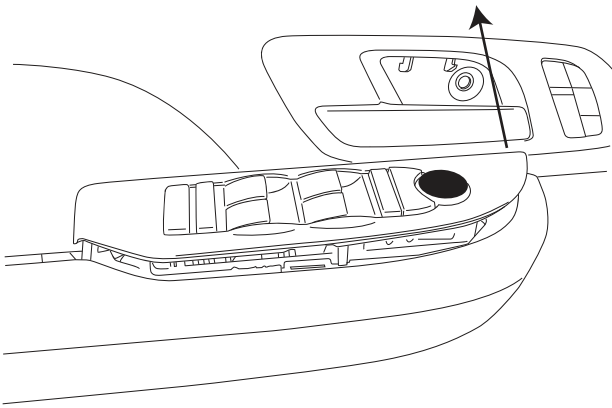

15

Remove all plugs from switchplate

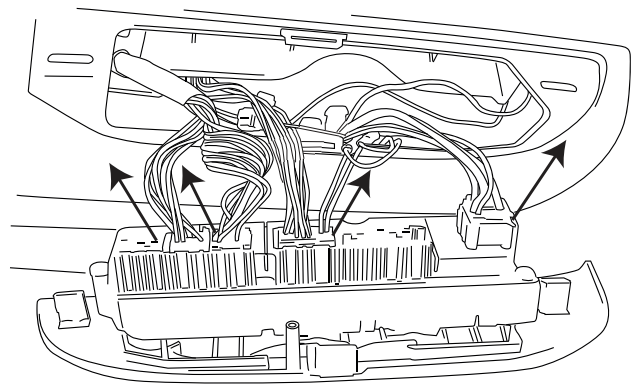

16

To remove door panel, first pry off door lock and plastic covers by handle and door latch. Remove the 3 door bolts and then remove door panel by pring loose all panel fasteners. Repeat on passenger side.

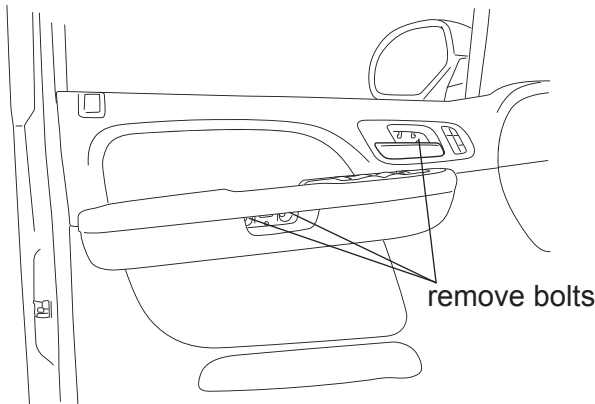

17

Remove door latch cable from door panel. Repeat on passenger side.

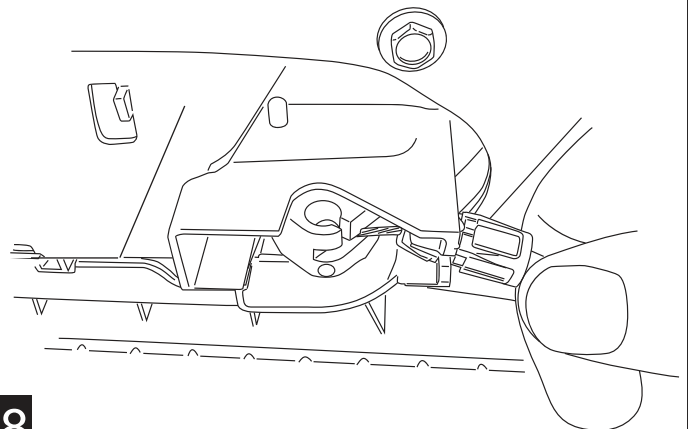

18

Pull back the door weather guard, unbolt speaker and unplug. Thread plastic tube through accordion. **Repeat on passenger side.**

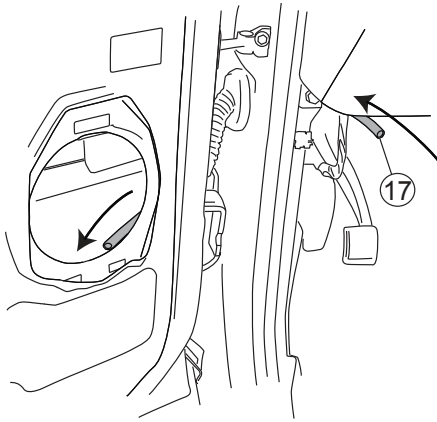

Feed longer wire of Step 11 through tube into door and pull out plastic tube on door side. Route wire along harness to switchplate.

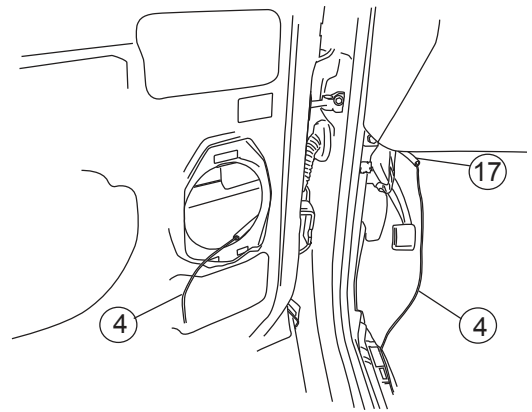

19

20

Locate the brown plug and using supplied Posi-Tap™ connector, splice into trigger wire.

2007-2008 Vehicles:

Drivers side: TAN wire- pin #11

Passengers side: LIGHT GREEN wire-pin#11

2009 & up Vehicles:

Drivers side: Gry/Blk wire- pin #13

Passenger side: Tan/Wht wire- pin # 13

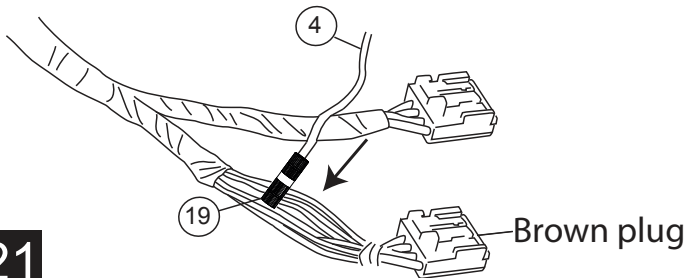

Insert plug from wire harness onto motor.

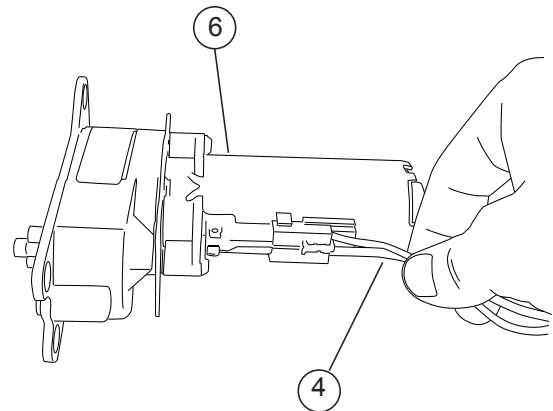

21

22

Slide rubber grommet on wire harness into slot of motor cover. Insert motor cover onto motor.

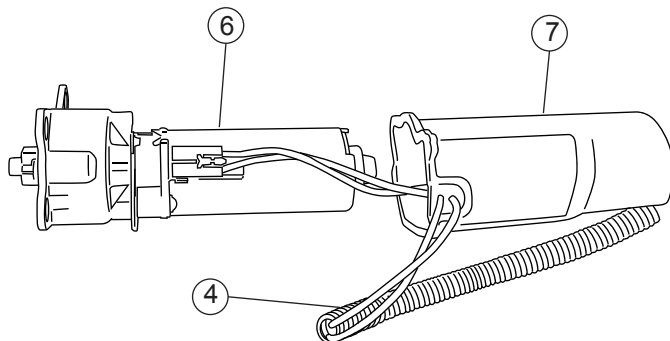

Insert plastic push pin rivets in mounting holes of motor cover. Use pliers to ease installation.

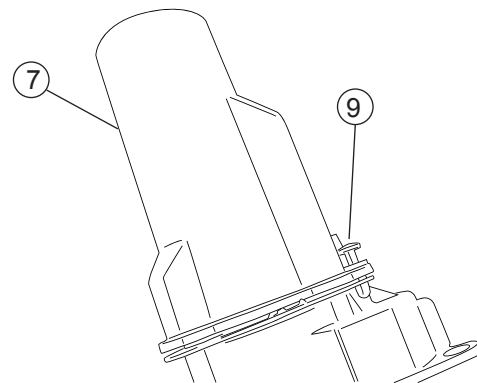

23

24

Slide motor assembly onto drive shaft and mounting bosses of driving linkage assembly. Use two (10) bolts to bolt motor down. Tighten to 16ft-lbs. Use electrical tape to cover any exposed wire from the motor.

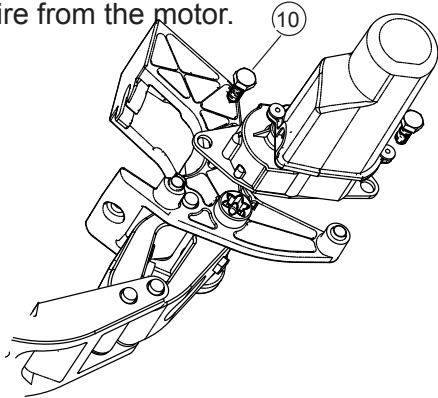

25

On each side of the vehicle measure from the front edge of door line on the pinch weld to the specified lengths below. Measure at 20" for front LED Light and 58" for rear LED Light.

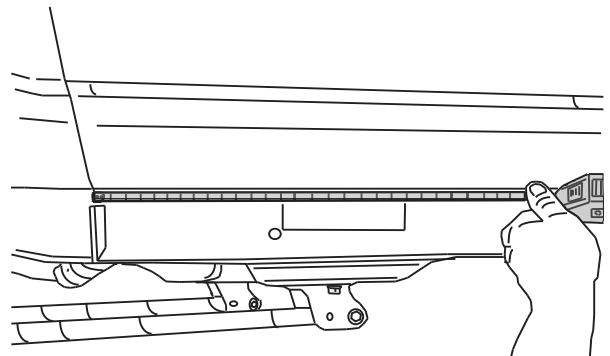

26

Affix lamp to rocker panel surface. Make sure the lamp is affixed to a clean, flat surface. There is a step down midway across the surface. Affix lamp just outside of step down.

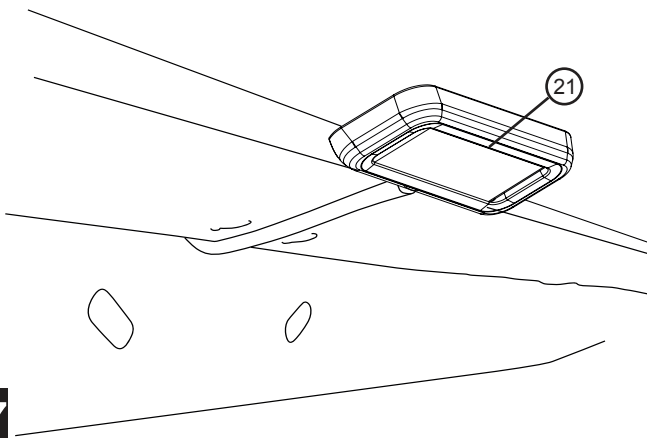

27

Using supplied butt connectors, connect the lamp wires. Red to Red, Black to Black. Once Crimped use heat gun to shrink tube.

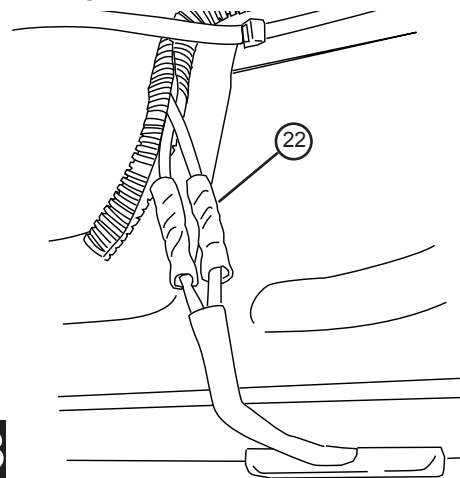

28

Close and wrap with conduit and electrical tape. Secure all loose wires with cable ties, with lamp wires pulled upward to avoid any wire snagging.

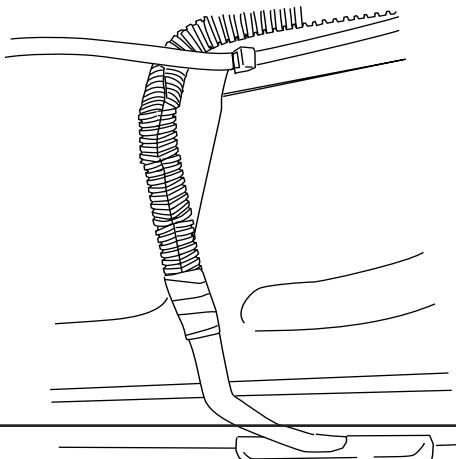

29

Reinstall fuse.

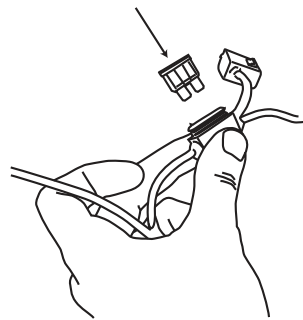

30

Check that all doors activate the Power Step and the LED Lights work when doors open and close. Reinstall any remaining trim panels.

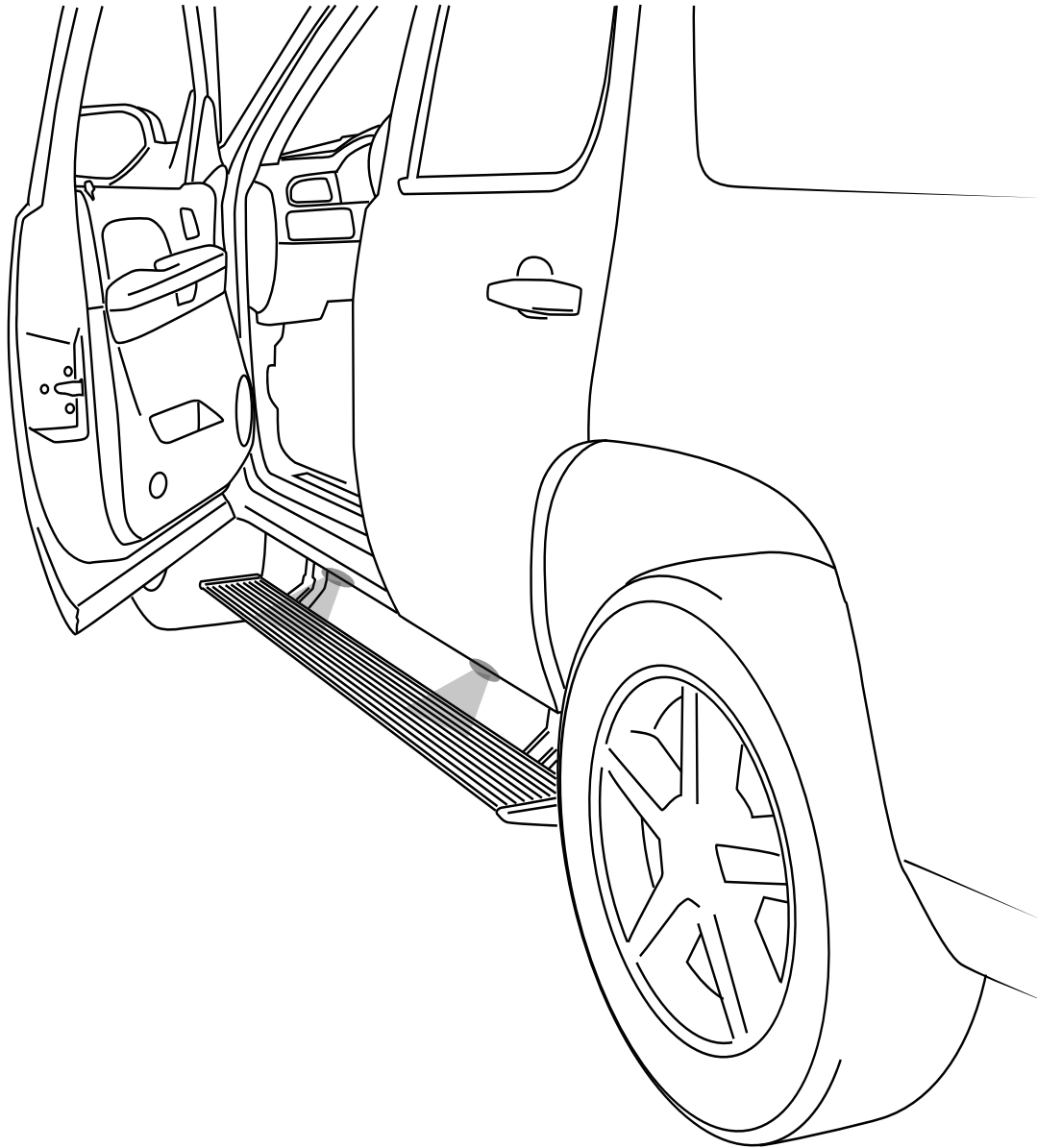

FINAL SYSTEM CHECK

Check that all doors activate the PowerStep and the LED lights work when doors open and close.

NORMAL OPERATION: When the doors open, PowerStep automatically deploys from under the vehicle.

When the doors are closed, PowerStep will automatically return to the stowed/retracted position. **Note that there is a 2-second delay before the PowerStep returns to the stowed/retracted position.**

CORRECT OPERATION OF LIGHTS: All four lamps will illuminate upon opening any door of vehicle. Lamps will stay on until restowing of both Power Steps or until 5 minutes has expired with the doors open. When the lights timeout after 5 minutes, they can be reilluminated by closing and opening any door of vehicle.

POWER-DEPLOYABLE RUNNING BOARDS OPERATION: AMP Research PowerStep running boards automatically move when the doors are opened to assist entering and exiting the vehicle.

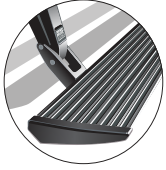

Automatic power deploy:

The running boards will extend down and out when the doors are opened.

Automatic power stow:

The running boards will return to the stowed position when the doors are closed. There will be a 2-second delay before the running boards move to the stowed position.

Automatic stop:

If an object is in the way of the moving running board, the running board will automatically stop. To reset, clear any obstruction, then simply open and close the door to resume normal operation.



Manually set in the deployed (OUT) position for access to the roof:

The running boards can be manually set in the deployed position by firmly holding the step down with your foot while at the same time closing the door. To resume normal operation, open and close the door.

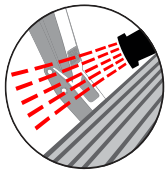

Maintenance: In adverse conditions, debris such as mud, dirt, and salt may become trapped in the running board mechanism, possibly leading to unwanted noise. If this occurs, manually set the running boards to the deployed position and flush the front and rear hinge arms with a high-pressure car wash wand. Avoid spraying the motors directly. After washing, apply silicone spray lubricant to the hinge pivot pins. Do not apply silicone, wax or protectants like Armor All® to the running board stepping surface.

Caution! Keep hands away when the running board is in motion.

5-YEAR LIMITED WARRANTY

AMP RESEARCH warrants this product to be free from defects in material and workmanship for FIVE (5) YEARS FROM DATE OF PURCHASE, provided there has been normal use and proper maintenance. This warranty applies to the original purchaser only. All remedies under this warranty are limited to the repair replacement of the product itself, or the repair or replacement of any component part thereof, found by the factory to be defective within the time period specified. The decision to repair or replace is wholly within the discretion of the manufacturer.

This warranty specifically excludes labor. If you have a warranty claim, first you must call our factory at the number below for instructions. You must retain proof of purchase and submit a copy with any items returned for warranty work. Upon completion of warranty work, if any, we will return the repaired or replaced item or items to you freight prepaid. Damage to our products caused by accidents, fire, vandalism, negligence, misinstallation, misuse, Acts of God, or by defective parts not manufactured by us, is not covered under this warranty.

ANY IMPLIED WARRANTIES OF MERCHANTABILITY AND/OR FITNESS FOR A PARTICULAR PURPOSE CREATED HEREBY ARE LIMITED IN DURATION TO THE SAME DURATION AND SCOPE AS THE EXPRESS WRITTEN WARRANTY. OUR COMPANY SHALL NOT BE LIABLE FOR ANY INCIDENTAL OR CONSEQUENTIAL DAMAGE.

Some states do not allow limitations on how long an implied warranty lasts, or the exclusion or limitation of incidental or consequential damages, so the above limitations or exclusions may not apply to you. This warranty gives you specific legal rights, and you may also have other rights that vary from state to state.

FOR WARRANTY ISSUES WITH THIS PRODUCT PLEASE CALL AMP RESEARCH CUSTOMER SERVICE 1-888-983-2204

WARNING

Be sure to read and precisely follow the provided instructions when installing this product. Failure to do so could place the vehicle occupants in a potentially dangerous situation. After installing or reinstalling, re-check to insure that the product is properly installed.