



INSTALLATION INSTRUCTIONS

71-3058

CHEVROLET / GMC / CADILLAC

**2007-08 Yukon Denali / Yukon XL Denali / Sierra Denali
Escalade / Escalade ESV / Escalade EXT**

V8-6.2L

2007-08 Suburban / Yukon XL / Avalanche

V8-5.3L / 6.0L

2007-08 Silverado / Sierra

V8-4.8L / 5.3L / 6.0L

2007-08 Tahoe / Yukon

V8-4.8L / 5.3L

NOTE: This kit was not designed to fit vehicles with a body lift.

TOOLS NEEDED:

Flat Blade Screwdriver
3mm Allen Wrench 10mm
1/2" Socket
5/8" Wrench
Ratchet
Extension
Socket
Pliers

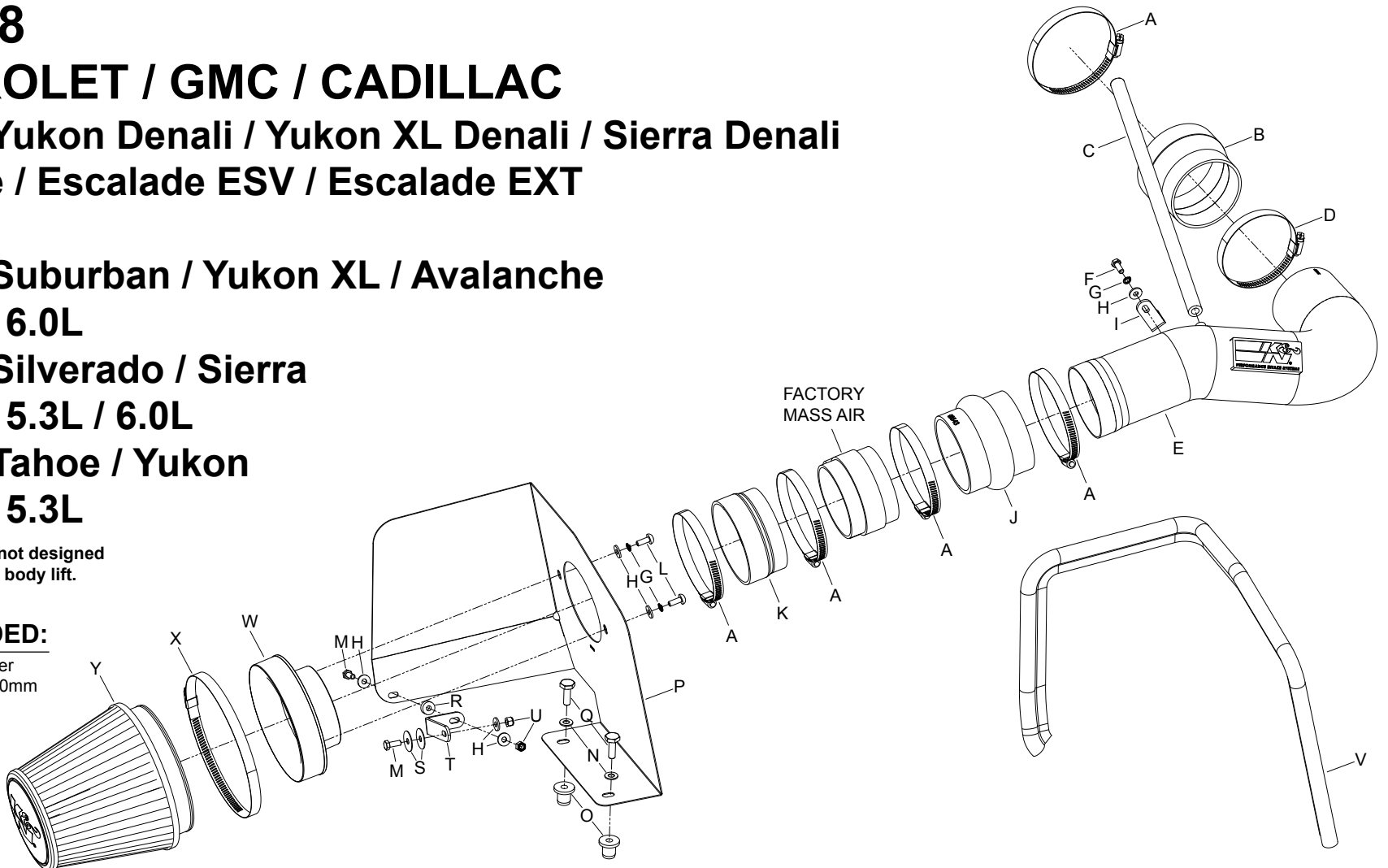

PARTS LIST:

Description	Qty.	Part #	Description	Qty.	Part #	Description	Qty.	Part #
A Hose Clamp #64, Black Zinc	5	08645K	J Hose; 3-5/8"ID X 3-3/8"L, Hump	1	08543	R Spacer; .625"OD X .250"ID	1	06555
B Hose; 4"ID To 3.5"ID X 3"L TPRD	1	08497	K Hose; 4" To 3-13/16" ID X 2"L	1	08618	S Washer; 1"D X 1/4 Hole Fender	2	08160
C Hose; 3/8"ID X 17"L	1	08404	L Bolt; M6 X 1.00 X 16MM, SS	2	07730	T Bracket; "L" Small, STL, TB/PC	1	010031
D Hose Clamp #56, Black Zinc	1	08620K	M Bolt; M6-1.00 X 25MM Hex HD	2	07704	U Nut; 6MM Nylock, Hexhead, SS	2	07512
E Intake Tube	1	27599TK	N Washer; 5/16"ID X 5/8"OD, Flat	2	08276	V Edge Trim (39")	1	102496
F Bolt; 6MM-1.00 X 16MM, SS	1	07812	O Insert; 5/16-18 X .600 OD X .730	2	088002	W Adaptor; 57-3058 #454	1	27300
G Washer; M6 Split Lock Zinc	3	1-3025	P Heat Shield	1	07635	X Hose Clamp #104, Black Zinc	1	08697K
H Washer; 1/4"ID X 5/8"OD -SAE	6	08275	Q Bolt; 5/16"-18 X 1"L, SS	2	07777	Y Air Filter	1	RU-3102-HBK
I Bracket; 57-3021, L-Bend, FIN	1	070812						

NOTE: FAILURE TO FOLLOW INSTALLATION INSTRUCTIONS AND NOT USING THE PROVIDED HARDWARE MAY DAMAGE THE INTAKE TUBE, THROTTLE BODY AND ENGINE.

TO START:

1. Turn off the ignition and disconnect the negative battery cable.

NOTE: Disconnecting the negative battery cable erases pre-programmed electronic memories. Write down all memory settings before disconnecting the negative battery cable. Some radios will require an anti-theft code to be entered after the battery is reconnected. The anti-theft code is typically supplied with your owner's manual. In the event your vehicles' anti-theft code cannot be recovered, contact an authorized dealership to obtain your vehicles anti-theft code.



2. Disconnect the mass air sensor electrical connection.



3. Lift up on the front of the engine cover to disengage from the mounting grommets. Then pull forward and remove the engine cover from the engine as shown.



4. Unhook the radiator hose mount from the intake tube.



5. Disconnect crank case vent hose from the valve cover as shown.

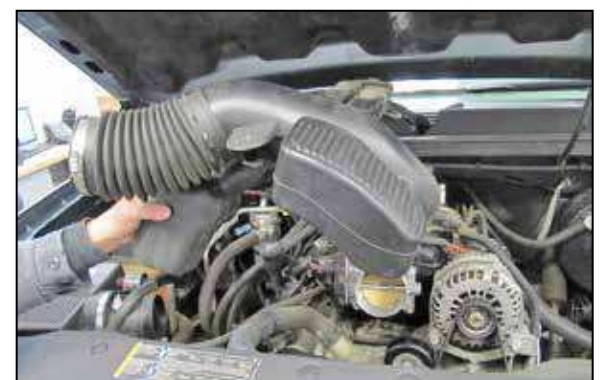

6. Loosen the hose clamps which secure stock intake tube to the throttle body and mass air sensor and then remove the intake tube from the vehicle.



7. Pull firmly upwards to release the air cleaner assembly from the mounting tray grommets, and then remove the assembly as shown.

NOTE: K&N Engineering, Inc., recommends that customers do not discard factory air intake.



8. Loosen the hose clamp and remove the mass air sensor from the air cleaner as shown.



9. Install the filter adapter onto the heat shield and secure with the provided hardware.

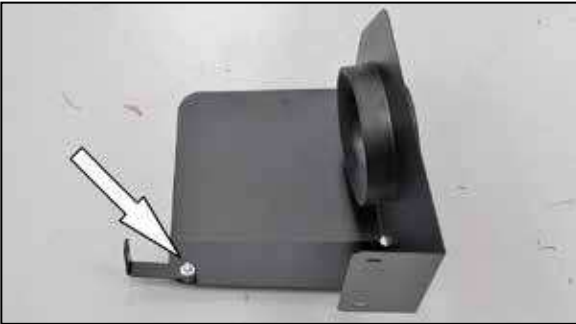

10. Install the "L" bracket (010031) onto the heat shield with the provided hardware as shown.

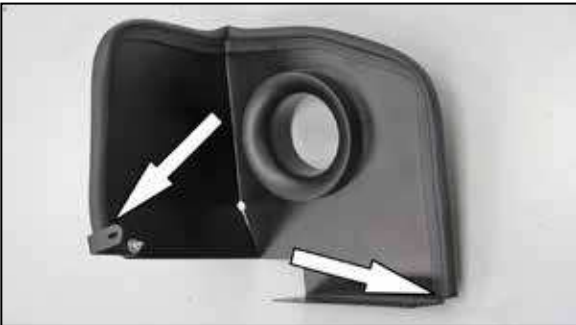

11. Install the provided edge trim onto the heat shield as shown.

NOTE: some trimming of the edge trim may be necessary.



12. Remove the two air box mounting grommets shown.

NOTE: Some vehicles may not be equipped with the front grommet and hole. Go to step 13.

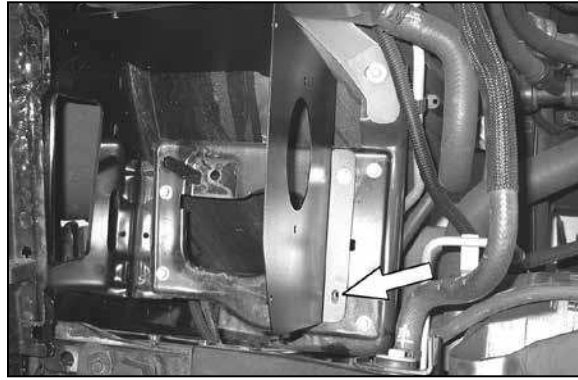

13. On vehicles not equipped with the front air box mounting grommet and hole, install the heat shield assembly as shown. Then use a marker to mark the mounting plate through the heat shield mounting hole.

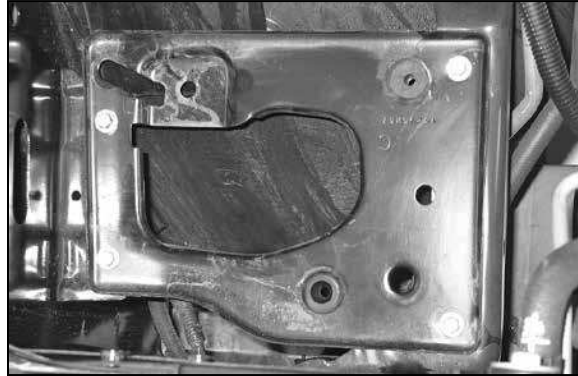

14. Remove the heat shield assembly and drill a 5/8" id hole through the marked location from step #13.



15. Install the two 5/16" inserted nuts into the air box mounting tray as shown.



16. Install the heat shield assembly onto the air box-mounting tray and secure to the 5/16" inserted nuts with the provided hardware as shown.



17. Secure the heat shield mounting bracket to the inner fender with the two fender washers and hardware as shown.



18. Install the silicone hose (08618) onto the filter adapter and secure with the provided hose clamp.



19. Install the silicone (08050) hose onto the throttle body and secure with the provided hose clamp.



20. Install the mass air sensor assembly into the silicone hose on the filter adapter and secure with provided hose clamp.



21. Install the silicone hump hose (08543) onto the mass air sensor and secure with the provided hose clamp as shown.



22. Install the "L" bracket (070812) onto the K&N® intake tube with the provided hardware as shown.



23. Install the K&N® intake tube into the silicone hose at the throttle body and mass air sensor and secure with the provided hose clamps.



24. Install the upper radiator hose mount onto the mounting bracket installed onto the K&N® intake tube.



25. Install the provided crank case vent hose onto the valve cover and then onto the K&N® intake tube as shown.



26. Install the K&N® filter as shown and secure with the provided hose clamp.



27. Reinstall the engine cover removed in step #3.



28. Reconnect the mass air sensor electrical connection.



29. Reconnect the vehicle's negative battery cable. Double check to make sure everything is tight and properly positioned before starting the vehicle.

30. It will be necessary for all K&N® high flow intake systems to be checked periodically for realignment, clearance and tightening of all connections. Failure to follow the above instructions or proper maintenance may void warranty.

ROAD TESTING:

1. Start the engine with the transmission in neutral or park, and the parking brake engaged. Listen for air leaks or odd noises. For air leaks secure hoses and connections. For odd noises, find cause and repair before proceeding. This kit will function identically to the factory system except for being louder and much more responsive.

2. Test drive the vehicle. Listen for odd noises or rattles and fix as necessary.

3. If road test is fine, you can now enjoy the added power and performance from your kit.

4. K&N Engineering, Inc., requires cleaning the Blackhawk Induction™ intake system's air filter element every 100,000 miles. When used in dusty or off-road environments, our filters will require cleaning more often. We recommend that you visually inspect your filter once every 25,000 miles to determine if the screen is still visible. When the screen is no longer visible some place on the filter element, it is time to clean it. To clean, purchase our Synthetic Filter Cleaner, part number 99-0624 and follow the easy instructions.

STREET LEGAL IN MOST STATES

**NOT LEGAL FOR USE IN CA & OTHER STATES
ADOPTING CA EMISSIONS STANDARDS**

See our catalog or knfilters.com for CARB status on each part for a specific vehicle

* FREE K&N® decal To register your warranty, please see us online at knfilters.com/register. FREE K&N® decal *