



INSTALLATION INSTRUCTIONS

71-1562

DODGE

2010-12 Ram 2500/3500

L6-6.7L DSL

NOTE: This kit was not designed to fit vehicles with a body lift.

TOOLS NEEDED:

Ratchet extension
13mm socket
10mm socket
8mm socket
7mm socket
13mm wrench
10mm wrench
3mm allen wrench
2.5mm allen wrench
flat blade screw driver

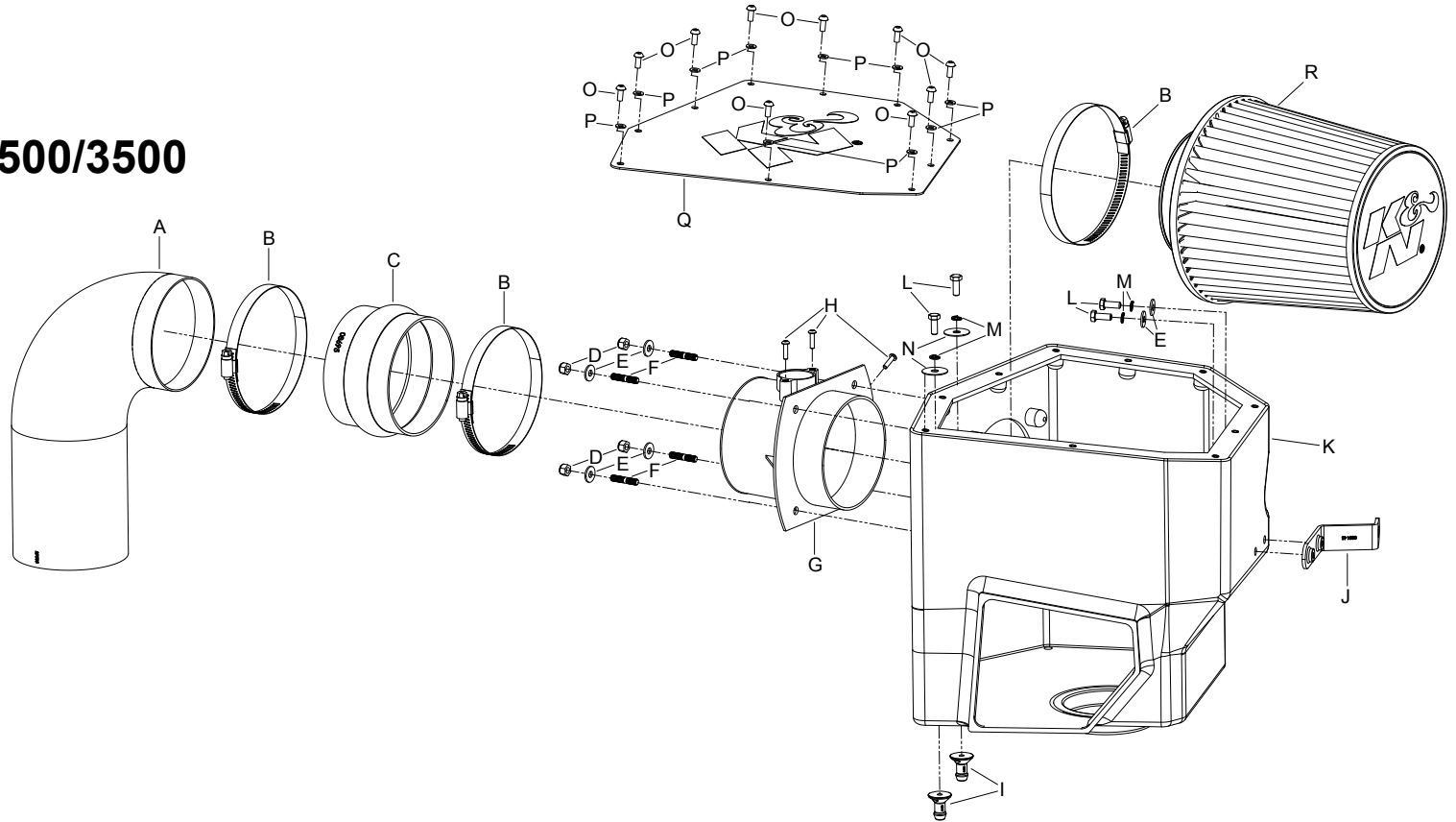

PARTS LIST:

Description	Qty.	Part #	Description	Qty.	Part #	Description	Qty.	Part #
A Intake Tube	1	27585TK	G Adapter; MAF Sensor Housing	1	088036	M Washer; M6 Split Lock Zinc	4	1-3025
B Hose Clamp #72	3	08671K	H Screw; M4-.7 X 16MM	3	07793	N Washer; 1"D X 1/4 Hole Fender	2	08160
C Hose; 4-1/2"ID X 3"L Hump	1	08695	I Mount, Plastic Airbox	2	8-186	O Bolt; M5-0.8 X 12MM, B/H, SS	10	07734
D Nut; 6MM Nylock, Hexhead, SS	4	07512	J Bracket; "Z", 63-1562, STL.	1	083145	P Washer; 5MM Flat, SS	10	08212
E Washer; 6MM Flat, SS	6	08269	K Air Box (IC)	1	087243A-UT	Q Air Box Lid	1	074080-1
F Stud; 6M-1 X 30 DBL Ended	4	1-107	L Bolt; 6MM -1.00 X 16MM, SS	4	07812	R Air Filter	1	RU-5283HBK

NOTE: FAILURE TO FOLLOW INSTALLATION INSTRUCTIONS AND NOT USING THE PROVIDED HARDWARE MAY DAMAGE THE INTAKE TUBE, THROTTLE BODY AND ENGINE.

TO START:

1. Turn off the ignition and disconnect the negative battery cable.

NOTE: Disconnecting the negative battery cable erases pre-programmed electronic memories. Write down all memory settings before disconnecting the negative battery cable. Some radios will require an anti-theft code to be entered after the battery is reconnected. The anti-theft code is typically supplied with your owner's manual. In the event your vehicles' anti-theft code cannot be recovered, contact an authorized dealership to obtain your vehicles anti-theft code.



2. Disconnect the Mass air sensor and temperature sensor electrical connections, and then unhook the wiring harness from the air box.



3. Loosen the hose clamp which secures the intake resonator to the turbo inlet hose.



4. Release the two clips securing the air box lid and then remove the air box lid and intake tube from the vehicle.



5. Remove the bolt which secures the lower air box to the core support.



6. Lift up the lower air box to dislodge it from the mounting grommets and then remove it from the vehicle.



7. Remove the core support bolt shown. **NOTE: This bolt will be reused in the next step.**



8. Install the air box mounting bracket (083145) onto the core support using the bolt removed in the previous step. **NOTE: Do not completely tighten the bolt at this time.**

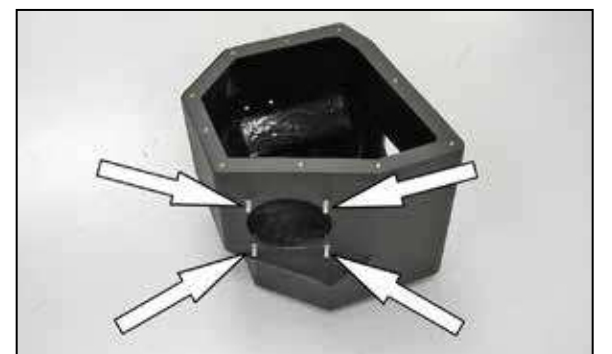

9. Install four of the provided 6mm studs into the K&N® air box as shown. **NOTE: Install the studs so the shorter threads are threaded into the air box inserts.**

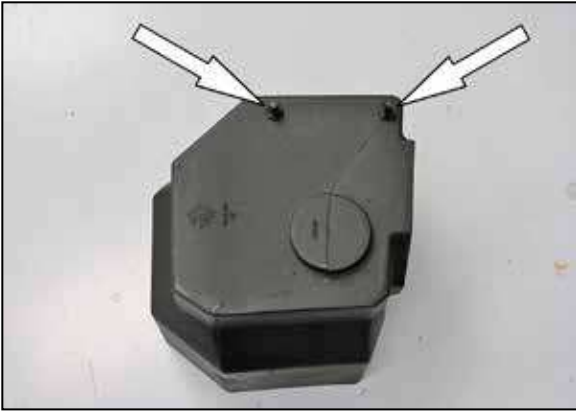

10. Install the two provided air box mounts to the bottom of the air box and secure with the provided hardware.



11. Install the air box so the mounting studs insert into the air box mounting grommets and then secure the air box to the mounting bracket installed in step #8. Tighten the mounting bracket bolts.



12. Remove the screws securing the mass air sensor and temperature sensor to the air box and then remove the mass air sensor and temperature sensor from the air box.



13. Install the mass air sensor and map sensor into the K&N mass air sensor housing using a twisting motion to aid installation and then secure with the provided hardware.



14. Set the K&N air filter into the K&N air box as shown.



15. Install the K&N mass air housing onto the mounting studs and into the K&N air filter. Secure the housing to the studs with the provided hardware and then secure the air filter with the hose clamp provided.



16. Install the provided silicone hose (08695) and hose clamps onto the K&N intake tube as shown. **NOTE: Do not completely tighten at this time.**



17. Install the K&N intake tube into the factory turbo inlet hose and then connect the K&N hose to the K&N mass air sensor housing. Secure the intake tube with the hose clamps provided.



18. Install the air box lid and secure with the provided hardware.



19. Reconnect the mass air sensor and temperature sensor electrical connection.



20. Reconnect the vehicle's negative battery cable. Double check to make sure everything is tight and properly positioned before starting the vehicle.

21. It will be necessary for all K&N high flow intake systems to be checked periodically for realignment, clearance and tightening of all connections. Failure to follow the above instructions or proper maintenance may void warranty.

ROAD TESTING:

1. Start the engine with the transmission in neutral or park, and the parking brake engaged. Listen for air leaks or odd noises. For air leaks secure hoses and connections. For odd noises, find cause and repair before proceeding. This kit will function identically to the factory system except for being louder and much more responsive.

2. Test drive the vehicle. Listen for odd noises or rattles and fix as necessary.

3. If road test is fine, you can now enjoy the added power and performance from your kit.

4. K&N Engineering, Inc., requires cleaning the Blackhawk Induction™ intake system's air filter element every 100,000 miles. When used in dusty or off-road environments, our filters will require cleaning more often. We recommend that you visually inspect your filter once every 25,000 miles to determine if the screen is still visible. When the screen is no longer visible some place on the filter element, it is time to clean it. To clean, purchase our Synthetic Filter Cleaner, part number 99-0624 and follow the easy instructions.

STREET LEGAL IN MOST STATES

**NOT LEGAL FOR USE IN CA & OTHER STATES
ADOPTING CA EMISSIONS STANDARDS**

See our catalog or knfilters.com for CARB status on each part for a specific vehicle

* FREE K&N decal To register your warranty, please see us online at knfilters.com/register. FREE K&N decal *