



# INSTALLATION INSTRUCTIONS

## Part Number: 63-1007-1

### AIRCHARGER PERFORMANCE KIT

Do not attempt to install this kit until you have read and completely understand these installation instructions. Proper installation requires basic automotive hand tools and a reasonable amount of mechanical knowledge.

#### INSTALLATION

- 1) Disconnect the vehicle's negative battery cable.
- 2) Remove the wing nut(s) that retains the air cleaner assembly.
- 3) Remove the heat stove tube, if applicable, at the air cleaner before removing the air cleaner assembly.  
**NOTE:** The heat stove will not be used with the Aircharger
- 4) Remove the entire air cleaner assembly along with the intake tube.  
**NOTE:** These parts will not be used with the Aircharger
- 5) **Vehicles with spacer tube:** Disconnect the crankcase vent line from the spacer tube. Install the vinyl cap plug provided to the spacer tube's small flange. **NOTE:** The long "Z" stud provided will be utilized on vehicles equipped with a spacer tube.  
**Vehicles without spacer tube:** Disconnect the crankcase vent line from the base of the air cleaner assembly.  
**NOTE:** The short "Z" stud provided will be utilized on the vehicles without a spacer tube.
- 6) **Vehicles with Single stud:** Remove and replace the stock stud at the throttle body with the appropriate "Z" stud.  
**Vehicles with Dual studs:** Using an 8mm wrench, remove the air cleaner studs from the throttle body bolts. Insert the appropriate "Z" stud, into the threaded hole located just in front of and in between the two throttle ports.
- 7) Install the provided 90 degree vent and nut to the base plate. Do not tighten completely at this time.
- 8) Install the new gasket and baseplate to the throttle body. (**NOTE:** The gasket is not needed with plastic spacers)
- 9) Connect the crankcase vent line to the 90 degree vent, position for best clearance and tighten.
- 10) Install the filter and lid.  
**NOTE:** No more than 1/2" of the stud should protrude through the lid.
- 11) For models that are equipped with an A.I.R. check valve, you must install the small clamp-on filter in place of the breather hose. (see figure 1 and 2 below.)  
**NOTE:** Oil the small clamp-on filter with the oil pack provided, prior to installing the filter.
- 12) Position for best clearance and tighten all hardware.
- 13) Re-connect battery cable. Double check to make sure that everything is tight and properly positioned before starting the vehicle.

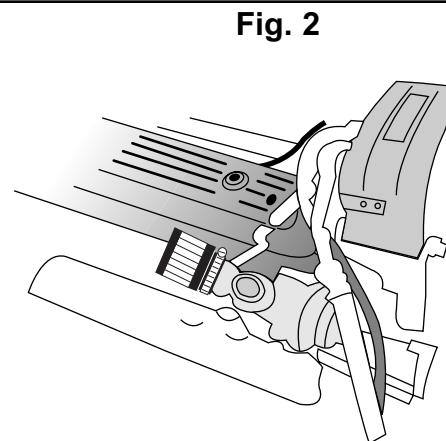
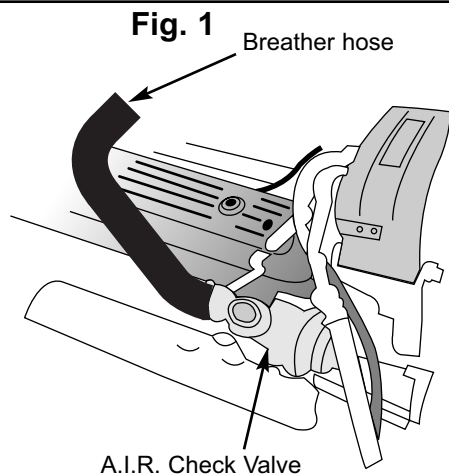

# ROAD TESTING

Start the engine with the transmission in neutral or park, and the emergency brake on. Listen for any air leaks or odd noises. If there are air leaks, make sure the hose connections are secure. If there are any odd noises, check for the cause and repair before proceeding. The K&N Aircharger Performance Kit will function identically to the factory air filter with the exception of being slightly louder than stock and much more responsive. If all preliminary checks are okay, then a road test is necessary. Listen carefully for rattling or other odd noises and fix as necessary. If the road test is fine, you can enjoy driving as normal with the added response and power. We suggest that the Aircharger element be checked periodically for dirt. This is now very easy due to the open element configuration. If the filter material is overly dirty, service it with a recharger kit, part number 99-5000 or 99-5050. If you have any questions or problems, inquire at your nearest K&N dealer, or direct to K&N Engineering at 800-858-3333.

Although this Aircharger kit was designed to work on a stock vehicle, in order to fully realize the performance potential of your vehicle, other engine systems may need to be enhanced. Headers and free-flowing exhaust systems ensure an airflow balance throughout the engine. A high performance computer chip will add extra fuel to the intake charge, without which, an engine can run in a lean condition and actually lose power. Other items such as performance pulleys, high-pressure fuel regulators, camshafts, etc. can also be helpful in obtaining the utmost performance from your vehicle.

## PARTS LIST

DESCRIPTION	QUANTITY
A 1/4-20 nylock nut	1
B Fender washer	1
C Rubber washer	1
D Top plate	1
E <b>Aircharger</b> element	1
F Base plate	1
G Base gasket	1**
H "Z" Stud, long	1**
I "Z" Stud, short	1**
J Nut, plastic	1
K Vent, 90 degree	1
L Clamp-on filter	1**
M Hose clamp	1**
N Vinyl cap plug	1**

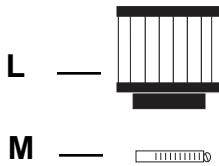
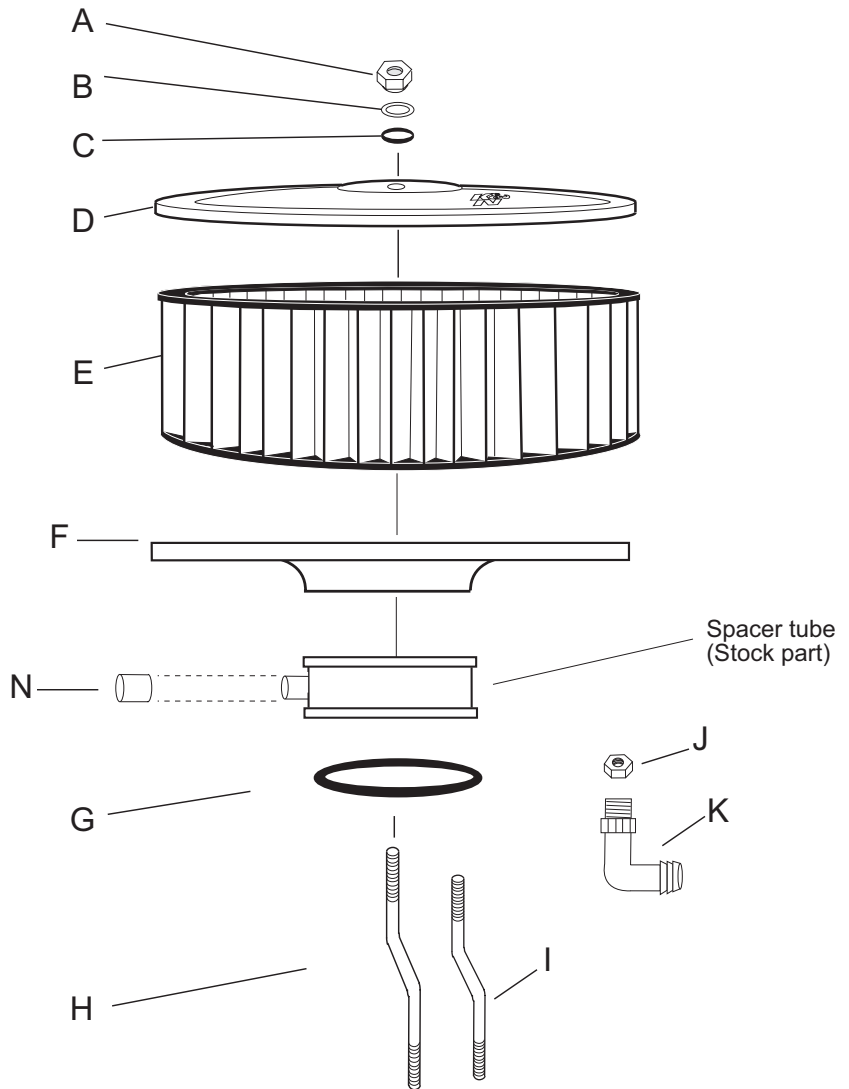

\*\* This item is not required for all applications.



\*Product is legal only for off-highway use(except in California or states that have adopted California emissions standards), competition racing, marine or for use on pre-emissions-controlled motor vehicles/motor-vehicle engines (pre 1966 vehicles certified to California standards, pre-1968 vehicles certified to federal standards and all pre-1968 foreign vehicles), per the manufacturer's application guide.